



















ROHRSCHELLEN

Befestigungssysteme

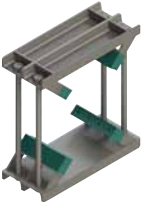
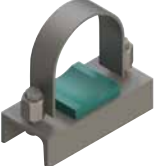
TUBE CLAMPS

Fastening Systems

<p>Rohrschellen DIN 3015 <i>Tube clamps DIN 3015</i></p> <p style="text-align: right;">3-4</p>	<p>Werkstoffeigenschaften <i>Material properties</i></p> <p>Sonderwerkstoffe für Rohr- und Schlauchschellen <i>Special-materials for Tube- and Hoseclamps</i></p> <p style="text-align: right;">5-7</p>	<p>Montagehinweise <i>Assembly Instructions</i></p> <p style="text-align: right;">10</p>
<p>Technische Daten <i>Technical Data</i></p> <p style="text-align: right;">11-12</p>	 <p>Rohrschellen Serie A <i>Tube clamps Series A</i></p> <p style="text-align: right;">13-27</p>	 <p>PP-CR der Korrosionshemmer <i>PP-CR the corrosion inhibitor</i></p> <p style="text-align: right;">14-15</p>
 <p>Sensorschellen Serie A <i>Sensor clamps Series A</i></p> <p style="text-align: right;">22</p>	 <p>Rohrschellen Serie 2+5 <i>Tube clamps Series 2+5</i></p> <p style="text-align: right;">28-29</p>	 <p>Rohrschellen Serie B <i>Tube clamps Series B</i></p> <p style="text-align: right;">31-37</p>
 <p>Rohrschellen Serie C <i>Tube clamps Series C</i></p> <p style="text-align: right;">39-50</p>	 <p>Befestigungsadaptor <i>Fixed adaptor</i></p> <p>Eine Schiene für alle <i>One rail for all</i></p> <p style="text-align: right;">51-57</p>	 <p>Rohrschellen mit Schalldämmeinlage <i>Tube clamps with noise protection insert</i></p> <p style="text-align: right;">58-64</p>
 <p>Multischellen <i>Multiclamps</i></p> <p style="text-align: right;">65-69</p>	 <p>Rohrschellen Serie O <i>Tube clamps Series O</i></p> <p style="text-align: right;">70-72</p>	 <p>Rohrbefestigung auf einem Zylinder <i>Tube fastening on a cylinder</i></p> <p style="text-align: right;">73-76</p>
 <p>Hydraulik-Stahlschelle <i>Hydraulic steel clamp</i></p> <p style="text-align: right;">77-80</p>	 <p>Stahl-Konstruktionsschelle mit Rohrunterlagen <i>Steel-construction clamp with tube saddles</i></p> <p style="text-align: right;">81-82</p>	 <p>Flachstahlbügel <i>Flat Steel U-bolts</i></p> <p style="text-align: right;">83-84</p>
 <p>Rundstahlbügel und Rohrunterlagen <i>U-Bolts and Tube saddles</i></p> <p style="text-align: right;">85-89</p>	 <p>Flachstahl-Rohrschellen <i>Flat steel tube clamps</i></p> <p style="text-align: right;">90</p>	 <p>Bezeichnungssystem <i>Labelling System</i></p> <p style="text-align: right;">91-92</p>

ROHRSCHELLEN NACH DIN 3015

Ausführung der Schellenkörper

Als Werkstoff für Schellenkörper sind ab Lager lieferbar:

- Polypropylen (Farbe dunkelgrün)
- Polyamid 6 (Farbe schwarz)
- TPE (Farbe schwarz)
- Aluminium

Die oberen und unteren Schellenhälften sind identisch. Die Innenseite der Schellen ist mit Rippen oder in glatter Ausführung lieferbar.

Rippen in der Innenfläche der Schellen wirken schlag- und vibrationsdämmend und nehmen Kräfte in Rohrachrichtung auf. Ein Spalt zwischen den Hälften bewirkt die Vorspannung des Rohres.

Für die Halterung von Schläuchen und Kabeln wird die Verwendung von Schellen mit glatter Innenfläche ohne Vorspannung empfohlen. Das Spaltmaß s_1 entfällt. Dadurch reduziert sich die Blockhöhe h_1 .



Ausführung der Metallteile

Bei Serie A und B sind standardmäßig Schrauben, Schienenmuttern und Deckplatten Chrom VI-frei verzinkt, Anschweißplatten phosphatiert, Tragschienen blank.

Bei Serie C sind standardmäßig alle Metallteile blank und phosphatiert.

Sämtliche Metallteile der einzelnen Baureihen sind in Edelstahlqualität W5 (AISI 316), ab Lager lieferbar.

Vom Standard abweichende Oberflächenbehandlung liefern wir auf Anfrage.

UNC-Gewinde sind auf Anfrage lieferbar.

Metrisches Gewinde	entsprechendes UNC-Gewinde
M 6	1/4 – 20 UNC
M 8	5/16 – 18 UNC
M 10	3/8 – 16 UNC
M 12	7/16 – 14 UNC
M 16	5/8 – 11 UNC
M 20	3/4 – 10 UNC
M 24	7/8 – 9 UNC
M 30	1 1/8 – 7 UNC

TUBE CLAMPS ACCORDING TO DIN 3015

Types of clamp bodies

The clamp bodies are available in these materials ex store:

- Polypropylene (dark green colour)
- Polyamide 6 (black colour)
- TPE (black colour)
- Aluminium

Upper and lower clamp halves are identical. The inside of the clamp is available with or without grooves.

Grooves on the inside of the clamps have a vibration and impact reducing effect and absorb force towards the direction of the tube axis. A spacing between both halves produces the prestress of the tube.

For the support of hoses and cables, we recommend to use clamps with an even inside without prestress. The spacing measure s_1 is not required. Thus, the block height h_1 is reduced.



Types of metal parts

As a regular feature of series A and B clamps, screws, rail nuts and cover plates are chromiumVI free zinc coated, welding plates phosphatized and mounting rails uncoated.

As a regular feature of series C clamps, all metal parts are uncoated and phosphatized.

All metal parts of the different construction series are available ex stock in stainless steel type W5 (AISI 316).

Other surface treatments are available upon request.

UNC-threads are available upon request.

Metric thread	corresponding UNC-thread
M 6	1/4 – 20 UNC
M 8	5/16 – 18 UNC
M 10	3/8 – 16 UNC
M 12	7/16 – 14 UNC
M 16	5/8 – 11 UNC
M 20	3/4 – 10 UNC
M 24	7/8 – 9 UNC
M 30	1 1/8 – 7 UNC

**Festigkeitsklassen der Schrauben
Strength classes of screws**

Schraubenart Type of screw	Werkstoff Material	Festigkeitsklasse Strength class
Schlitzschraube SL Slotted head screw SL	Stahl / Steel	4.8 (nach DIN EN ISO 898-1)
	A2	A2-70 (nach DIN EN ISO 3506-1)
	A4	A4-70 (nach DIN EN ISO 3506-1)
Sechskantschraube SSL/SS Hexagon head screw SSL/SS	Stahl / Steel	8.8 (nach DIN EN ISO 898-1)
	A2	A2-70 (nach DIN EN ISO 3506-1)
	A4	A4-70 (nach DIN EN ISO 3506-1)
Innensechskantschraube IS Hexagon socket head screw IS	Stahl / Steel	8.8 (nach DIN EN ISO 898-1)
	A2	A2-70 (nach DIN EN ISO 3506-1)
	A4	A4-70 (nach DIN EN ISO 3506-1)

Bestellzeichen

In die Bestellzeichen für RSB-Schellenhälften sowie für komplette Rohrschellen ist die Serienbezeichnung, die Werkstoffbezeichnung und die Form der Innenfläche eingearbeitet.

Bezeichnungsbeispiel:

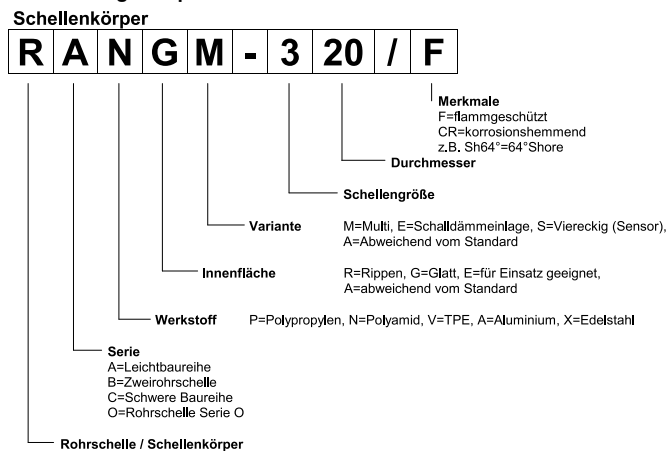

- Vollgummi bei Serie A und B, glatte Innenfläche
- Aluminium bei Serie A Größe 0 bis 6 und Serie C Größe 1 bis 8
- Glatte Innenfläche bei Serie C bis Größe 8, Schellen aus Aluminium mit Rippen (R), Glatte Innenfläche bei Serie A Größe 1 bis 8

Zubehör / Metall

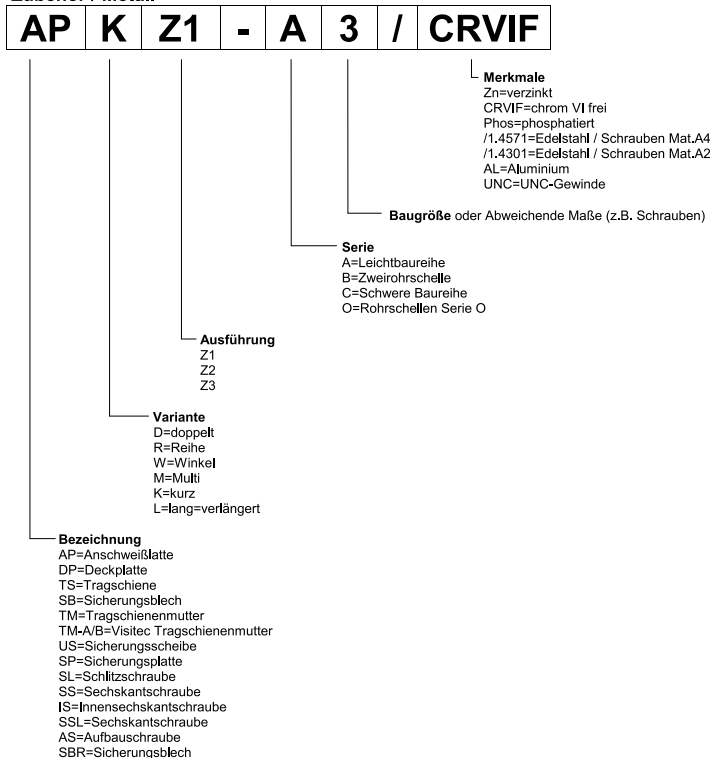

Zulassungen

Germanischer Lloyd, Lloyd's Register of Shipping, Bureau Veritas, ABS (American Bureau of shipping)

Order codes

The order codes for RSB clamp-halves as well as for complete tube clamps incorporate the serial indication, material description and interior surface.

Example of description:

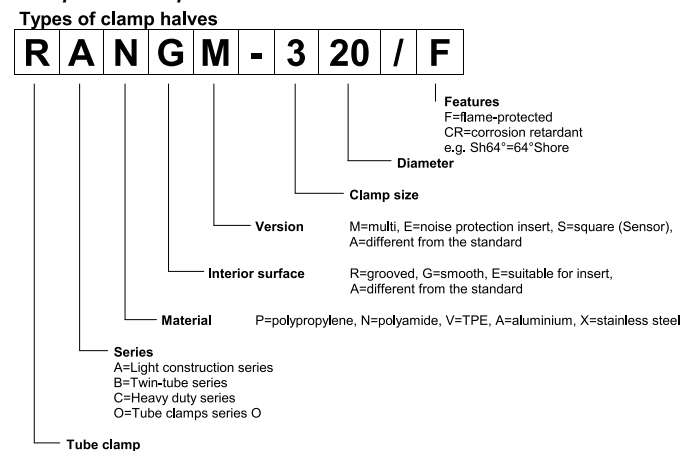

- Rubber for series A and B, inside smooth
- Aluminium for series A size 0 to 6 and series C size 1 to 8
- Smooth interior surface in series C to size 8, Aluminium clamps in a grooved design (R), Inside smooth series A size 1 to 8

Types of metal parts

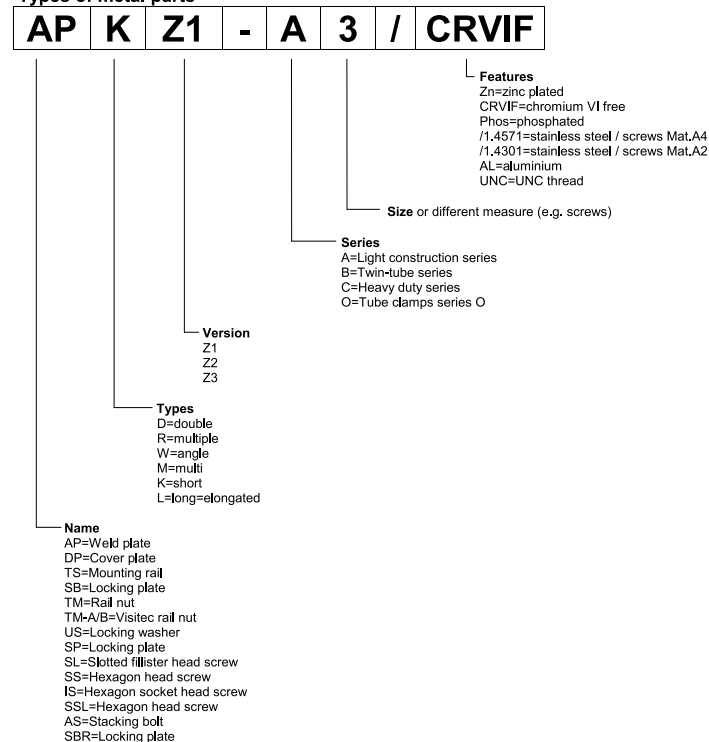

Registration

German Lloyd, Lloyd's Register of Shipping, Bureau Veritas, ABS (American Bureau of shipping)

WERKSTOFF / MECHANISCHE EIGENSCHAFTEN SUBSTANCE / MECHANICAL PROPERTIES		Polypropylen Polypropylene (PP)	Polyamid Polyamide (PA 6)	Aluminium Aluminium (Al)	Thermoplastisches Elastomer Thermoplastic elastomer
Dichte	Density	0,90 g/cm ³	1,10 g/cm ³	2,65 g/cm ³	0,97 g/cm ³
Kerbschlagzähigkeit nach Charpy bei 23 °C	Impact value at 23 °C	7 kJ/m ² (ISO 179/1eA)	8 kJ/mm ² (ISO 179/1eA)		
Kerbschlagzähigkeit nach Charpy bei -20 °C	Impact value at -20 °C	3 kJ/m ² (ISO 179/1eA)			
E-Modul (Zug)	Modulus of elasticity	1.400 N/mm ² (ISO 527)	2.000 N/mm ² (ISO 527)	72.000 N/mm ²	
Streckspannung bzw. Zugfestigkeit (Rm)	Yield stress resp. tensile strength (Rm)	28 N/mm ² (ISO 527)	50 N/mm ² (ISO 527)	>240 N/mm ²	5,2 ... 8,8 N/mm ² (ASTM D412)

THERMISCHE EIGENSCHAFTEN THERMAL PROPERTIES					
Temperaturbeständigkeit	Temperature resistance	-30 ... +90 °C	-40 ... +120 °C	-40 ... +300 °C	-50 ... +120 °C

CHEMISCHE EIGENSCHAFTEN CHEMICAL PROPERTIES					
Säuren	Weak acids	bedingt beständig limited resistant	bedingt beständig limited resistant	bedingt beständig limited resistant	beständig resistant
Laugen	Weak alkalis	bedingt beständig limited resistant	bedingt beständig limited resistant	bedingt beständig limited resistant	beständig resistant
Alkohole	Alcohol	beständig resistant	beständig resistant	beständig resistant	beständig resistant
Benzin	Petrol	bedingt beständig limited resistant	beständig resistant	beständig resistant	bedingt beständig limited resistant
Mineral-Öl	Mineral oils	bedingt beständig limited resistant	beständig resistant	beständig resistant	beständig resistant
Sonstiges Öl	Other oils	beständig resistant	beständig resistant	beständig resistant	beständig iresistant

Andere Werkstoffe auf Anfrage / Other materials on request

Die genannten Daten sind Durchschnittswerte und gelten nur als unverbindliche Hinweise, auch in Bezug auf etwaige Schutzrechte Dritter, und befreien Sie nicht von der eigenen Prüfung der von uns gelieferten Produkte auf ihre Eignung.

Diese Werte können nur bedingt zu Konstruktionszwecken verwendet werden.

Die Anwendung der Produkte erfolgt außerhalb unserer Kontrollmöglichkeiten und liegt daher ausschließlich in Ihrem Verantwortungsbereich. Sollte dennoch eine Haftung in Frage kommen, so ist dies für alle Schäden auf den Wert der von uns gelieferten und von Ihnen eingesetzten Ware begrenzt.

Selbstverständlich gewährleisten wir die einwandfreie Qualität unserer Produkte nach Maßgabe unserer Allgemeinen Verkaufs- und Lieferbedingungen.

The outlined particulars are approximate values and are only valid as references, which are not binding, also with regard to possible protection of third parties, and they do not exempt you from your own examination of suitability of the products delivered by us.

Therefore, these values can only be used in a limited sense for construction purposes.

The application of the products is carried out outside our control, and therefore, is exclusively subject to your own area of responsibility. If, however, liability should be possible, it would be limited for all damages to the value of the goods supplied by us and in use by you.

It goes without saying, that we guarantee the perfect quality of our products according to our general sales and delivery conditions.

VORBEUGENDER BRANDSCHUTZ
PREVENTIVE FIRE PROTECTION

Material: Material:		PA66-F
EN 45545-2		
T01 EN ISO 4589-2:	Sauerstoffgehalt Oxygen Index	OI = 35,5 %
T10.03 EN ISO 5659-2:	25 kW/m ²	D _s max. = 124
T12 NF X 70 100-1 & -2:	600 °C	CIT _{NLP} = 0,51
Erfüllung des Anforderungssatzes R22 für die Gefährdungsstufe: Compliance of the requirement set R22 for the hazard level:		HL1 - HL2 - HL3
Erfüllung des Anforderungssatzes R23 für die Gefährdungsstufe: Compliance of the requirement set R23 for the hazard level:		HL1 - HL2 - HL3
Erfüllung des Anforderungssatzes R24 für die Gefährdungsstufe: Compliance of the requirement set R24 for the hazard level:		HL1 - HL2 - HL3
Erfüllung des Anforderungssatzes R26 für die Gefährdungsstufe: Compliance of the requirement set R26 for the hazard level:		HL1 - HL2 - HL3

Material: Material:		PP-F
EN 45545-2		
T01 EN ISO 4589-2:	Sauerstoffgehalt Oxygen Index	OI = 38,7 %
T10.03 EN ISO 5659-2:	25 kW/m ²	D _s max. = 48
T12.NF X 70 100-1 & -2:	600 °C	CIT _{NLP} = 0,15
Erfüllung des Anforderungssatzes R22 für die Gefährdungsstufe: Compliance of the requirement set R22 for the hazard level:		HL1 - HL2 - HL3
Erfüllung des Anforderungssatzes R23 für die Gefährdungsstufe: Compliance of the requirement set R23 for the hazard level:		HL1 - HL2 - HL3
Erfüllung des Anforderungssatzes R24 für die Gefährdungsstufe: Compliance of the requirement set R24 for the hazard level:		HL1 - HL2 - HL3
Erfüllung des Anforderungssatzes R26 für die Gefährdungsstufe: Compliance of the requirement set R26 for the hazard level:		HL1 - HL2 - HL3

Weitere Brandschutzprüfungen auf Anfrage.
 Further fire safety tests on request.

VORBEUGENDER BRANDSCHUTZ
PREVENTIVE FIRE PROTECTION

Material: Material:		TPE-F
EN 45545-2		
T01 EN ISO 4589-2	Sauerstoffgehalt Oxygen Index	OI = 33,4 %
T10.03 EN ISO 5659-2:	25 kW/m ²	D _s max. = 79
T12 NF X 70 100-1 & -2:	600 °C	CIT _{NLP} = 0,15
Erfüllung des Anforderungssatzes R22 für die Gefährdungsstufe: Compliance of the requirement set R22 for the hazard level:		HL1 - HL2 - HL3
Erfüllung des Anforderungssatzes R23 für die Gefährdungsstufe: Compliance of the requirement set R23 for the hazard level:		HL1 - HL2 - HL3
Erfüllung des Anforderungssatzes R24 für die Gefährdungsstufe: Compliance of the requirement set R24 for the hazard level:		HL1 - HL2 - HL3
Erfüllung des Anforderungssatzes R26 für die Gefährdungsstufe: Compliance of the requirement set R26 for the hazard level:		HL1 - HL2 - HL3

Weitere Brandschutzprüfungen auf Anfrage.
 Further fire safety tests on request.

SCHIFFSBAU UND OFFSHORE LÖSUNGEN

KORROSIONSHEMMEND UND SCHALLDÄMMEND | NACH DIN 3015

SHIPBUILDING AND OFFSHORE SOLUTIONS

CORROSION-INHIBITING AND SOUND-ABSORBING | IN ACCORDANCE WITH DIN 3015

DIE LÖSUNG FÜR SCHIFFSBAU UND OFFSHORE

- Vibrationsdämmung und Körperschall-entkopplung im System
- Korrosionsschutz getestet gemäß DIN EN ISO 9227
- Längere Standzeiten
- Höhere Wartungsintervalle
- Längere Lebensdauer der Rohre und Hydraulikleitungen

THE SHIPBUILDING AND OFFSHORE SOLUTION

- Systematic vibration insulation and structure-borne sound insulation
- Certified corrosion inhibitor in line with DIN EN ISO 9227
- Longer service life
- Increased maintenance intervals
- Greater durability of tubes and hydraulic lines

IN DER NORM KONFORM ZULASSUNGEN

- Germanischer Lloyd
- ABS (American Bureau of shipping)
- Bureau Veritas
- Lloyd's Register of Shipping

STANDARDS COMPLIANCE APPROVALS

- Germanischer Lloyd
- ABS (American Bureau of shipping)
- Bureau Veritas
- Lloyd's Register of Shipping

PRODUKTE PRODUCTS



- | | |
|---|---|
| 1. Rohrschellen mit Schalldämmeinlage (Seite 58-64) | 1. Tube clamps with noise protection insert (pages 58-64) |
| 2. Rohrschellen Serie 2+5 (Seite 28-29) | 2. Tube clamps series 2+5 (pages 28-29) |
| 3. PP-CR®-Schelle (Seite 14-15) | 3. PP-CR® tube clamp (pages 14-15) |
| 4. Rundstahlbügel (Seite 85-89) | 4. U-bolt (pages 85-89) |

DER KORROSIONSHEMMER ROHRSCHELLEN AUS PP-CR®

EDELSTAHLROHR (1.4571) NACH 4500 STD. SALZSPRÜHNEBELTEST

THE CORROSION INHIBITOR TUBE CLAMPS MADE FROM PP-CR®

STAINLESS STEEL TUBE (1.4571) AFTER 4,500 HOURS SALT SPRAY TEST

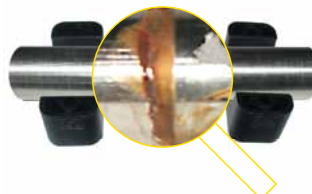

Resultat mit Standard-Polypropylen
Result with standard polypropylene



Resultat mit PP-CR®
Result with PP-CR®

SICHERHEIT MIT SYSTEM!

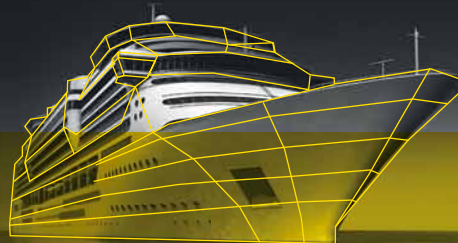

FLAMMGESCHÜTZTE ROHRSCHELLEN

FÜR ERHÖHTE SICHERHEIT VON SCHIENEN-
FAHRZEUGEN | NACH DIN 3015

FLAME PROTECTED TUBE CLAMPS

FOR IMPROVED RAILWAY VEHICLE SAFETY | IN ACCORDANCE WITH DIN 3015

DIE VORTEILE

- Mehr Sicherheit für Schienenfahrzeuge
- Flammgeschützt nach DIN 5510-2, NF F 16-101, BS 6853, UL 94
- System 2+5. Nur 2 Baugrößen für die Rohrdurchmesser 6 – 42 mm
- Platten und Schienen in Stahl und Edelstahl

IN DER NORM KONFORM

FLAMMGESCHÜTZTE ROHRSCHELLEN
NACH DIN 3015 GEPRÜFT GEMÄSS

- BS 6853
- DIN 5510-2
- DIN EN 45545
- UL 94
- NF F 16-101

MIT SYSTEM FÜR HÖHERE SICHERHEIT!

Das bekannte Rohrschellen-Programm von RSB® ist jetzt durch die flammgeschützte Ausführung die ideale Lösung für den Transport- und Railway-Markt. Das bedeutet mehr Sicherheit und Effizienz für Schienenfahrzeuge.

THE ADVANTAGES

- Improved railway vehicle safety
- Flame protected in accordance with DIN 5510-2, NF F 16-101, BS 6853, UL 94
- 2+5 system. Only 2 sizes for tube diameters 6 – 42 mm
- Plates and rails in steel and stainless steel

STANDARDS COMPLIANCE

FLAME PROTECTED TUBE CLAMPS
DIN 3015 CERTIFICATION IN LINE WITH

- BS 6853
- DIN 5510-2
- DIN EN 45545
- UL 94
- NF F 16-101

SYSTEMATIC FOR IMPROVED SAFETY!

The well-known tube clamp range from RSB® has just got bigger. Now available as a flame protected version, it is the ideal solution for the transport and railway market. This means improved safety and efficiency for rail vehicles.



PRODUKTE PRODUCTS

1. Multischelle Serie A (Seite 65-69)
2. Rohrschelle Serie A (Seite 13-27)
3. Visitec (Seite 21)
1. Multiclamp series A (pages 65-69)
2. Tube clamp series A (pages 13-27)
3. Visitec (page 21)

SICHERHEIT MIT SYSTEM!



MONTAGE

Montage auf Anschweißplatten

Anschweißplatten auf einer mit der Belastung abgestimmten Unterlage anschweißen. Hierbei ist auf die Ausrichtung der Schelle zu achten.

Untere Schellenhälfte auf Anschweißplatte klemmen, Rohr einlegen, zweite Schellenhälfte aufsetzen und mit den Schrauben festziehen. Auf Vorspannung achten (Schellenhälften dürfen sich nach der Montage nicht berühren)!

Nicht mit aufgesetzter Kunststoff-Schelle schweißen! Verlängerte Anschweißplatten können mit der Unterlage verschraubt werden.



Montage auf Tragschienen

Tragschienen sind in vier unterschiedlichen Höhen verfügbar und werden wahlweise in Stücken zu 1 oder 2 m geliefert.

Tragschiene anschweißen oder mit Befestigungswinkel anschrauben. Tragschienenmutter in Schiene einführen und bis zum Anschlag drehen. Bei schwerer Baureihe nur einschieben.

Untere Schellenhälfte auf Tragschienenmutter aufkleben, Rohr einlegen, zweite Schellenhälfte aufsetzen und mit den Schrauben festziehen. Vor dem Festziehen der Schrauben ist eine Positionierung der Schelle möglich. Auf Vorspannung achten (Schellenhälften dürfen sich nach Montage nicht berühren)!



Aufbaumontage

RSB-Schellen erlauben die Montage mehrerer Schellen gleicher Baugröße, auch unterschiedlicher Rohrdurchmesser übereinander. Die Aufbaumontage erfolgt durch spezielle Aufbauschrauben, die durch Sicherungsplatten gegen Verdrehen gesichert werden.

Untere Schellenhälfte auf Anschweißplatte oder Tragschiene aufkleben, Rohr einlegen, obere Schellenhälfte aufsetzen und mit Aufbauschrauben festziehen. Die Aufbauschraube ragt über die obere Schellenhälfte hinaus. Durch Auflegen eines Sicherungsbleches wird ein Verdrehen der Aufbauschraube verhindert.

Zweite Rohrschelle auf die Aufbauschrauben aufkleben u.s.w.

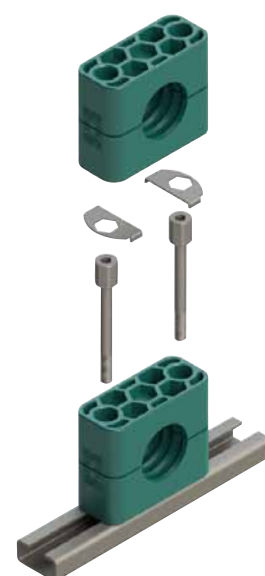

ASSEMBLY INSTRUCTION

Assembly on metal welding plates

Place welding plates on a base appropriate for the load. Make sure that the clamps are properly aligned.

Clamp lower clamp half onto welding plate, insert tube, place upper clamp half onto lower half and fasten with the screws. Attention must be paid to the prestress (after completed assembly, clamp halves must not be in contact)!

Do not weld with fitted plastic clamp! Extended welding plates may be screwfastened to the base.

Assembly on mounting rails

Mounting rails are available in four different heights and come in pieces of 1m or 2 m length, as required.

Weld on mounting rail or screw-fasten with fastening angle bracket. Insert mounting rail nuts in rail and turn until stop. For heavy duty construction series, nuts are simply pushed in.

Clamp lower clamp half on mounting rail nuts, insert tube, place upper clamp half onto lower half and fasten with the screws. Before fastening the screws, the clamp may still be positioned. Attention must be paid to the prestress (after completed assembly, the clamp halves must not be in contact)!

Stacking assembly

RSB-Clamps allow the assembly of multiple clamps of the same construction size and of different tube diameters one above the other. The construction assembly is carried out with special fixing screws that are secured against twisting by applying a locking plate.

Clamp lower clamp half on welding plate or mounting rail respectively, insert tube, place upper clamp half on lower half and fasten with fixing screws.

The fixing screw juts out from the upper clamp half. The application of a locking plate securely fastens the fixing screw and prevents twisting.

Clamp on second clamp half on to the fixing screws etc.

Schraubenanzugsmomente und axiale Rohrhaltekräfte
Screw tightening torque and axial pipe shearing forces



Die angegebenen Schraubenanzugsmomente und axialen Rohrhaltekräfte beziehen sich auf Montage mit Deckplatten und Außensechskantschrauben nach ISO 4014/4017 (DIN 931/933). Die axiale Rohrhaltekraft (gemäß DIN 3015 Teil 10) ist ein Mittelwert, ermittelt aus drei Versuchen bei 23°C mit einem Stahlrohr nach DIN 2448 aus St 37, bei dem Haftreibung vorausgesetzt wird. Bei Belastung der RSB-Schelle in axialer Rohrrichtung mit der angegebenen Prüfkraft (F) gleitet das Rohr in der Schelle nicht.

The indicated screw tightening torque and axial pipe shearing forces refer to the assembly with cover plates and hexagon head bolts according to ISO 4014/4017 (DIN 931/933). The axial pipe shearing force (according to DIN 3015, part 10) is an average value, determined by three tests made with a steel pipe according to DIN 2448 of St 37, for which static friction is presupposed (temperature during tests: 23°C). When loading the RSB clamp with the indicated test force (F) in axial pipe direction, the pipe does not slide in the clamp.

Leichte Baureihe (DIN 3015, Teil 1) / Light series (DIN 3015, part 1)

Baugröße Size	Befestigungs- schraube Fixing screw ISO 4014/4017 (DIN 931/933)	Polypropylen / Polypropylene		Polyamid / Polyamide		Aluminium / Aluminium	
		Schraubenanzugs- moment (Nm) Screw tightening torque (Mn)	Rohrhaltekraft F (kN) Pipe shearing force F (kN)	Schraubenanzugs- moment (Nm) Screw tightening torque (Mn)	Rohrhaltekraft F (kN) Pipe shearing force F (kN)	Schraubenanzugs- moment (Nm) Screw tightening torque (Mn)	Rohrhaltekraft F (kN) Pipe shearing force F (kN)
0	M 6	8	0,6	10	0,6		
1		8	1,1	10	0,7	12	4,2
2		8	1,2	10	0,8	12	4,3
3		8	1,4	10	1,6	12	4,8
4		8	1,5	10	1,7	12	5,0
5		8	1,9	10	2,0	12	7,3
6		8	2,0	10	2,5	12	8,9
7		8	2,3	10	3,2		
8		8	2,6	10	3,5		

Schwere Baureihe (DIN 3015, Teil 2) / Heavy series (DIN 3015, part 2)

Baugröße Size	Befestigungs- schraube Fixing screw ISO 4014/4017 (DIN 931/933)	Polypropylen / Polypropylene		Polyamid / Polyamide		Aluminium / Aluminium	
		Schraubenanzugs- moment (Nm) Screw tightening torque (Mn)	Rohrhaltekraft F (kN) Pipe shearing force F (kN)	Schraubenanzugs- moment (Nm) Screw tightening torque (Mn)	Rohrhaltekraft F (kN) Pipe shearing force F (kN)	Schraubenanzugs- moment (Nm) Screw tightening torque (Mn)	Rohrhaltekraft F (kN) Pipe shearing force F (kN)
1	M 10	12	1,6	20	4,2	30	12,1
2		12	2,9	20	4,5	30	15,1
3		15	3,3	25	5,1	35	15,5
4	M 12	30	8,2	40	9,3	55	29,4
5	M 16	45	11,0	55	15,8	120	34,8
6	M 20	80	14,0	150	21,0	220	50,0
7	M 24	110	28,0	200	32,0	250	70,6
8	M 30	180	40,0	350	48,0	500	84,5
9	M 30	200	119,0	370	125,0	500	181,5
10	M 30	270	168,0	450	180,0	600	244,5

Doppel-Baureihe (DIN 3015, Teil 3) / Double Series (DIN 3015, part 3)

Baugröße Size	Befestigungs- schraube Fixing screw ISO 4014/4017 (DIN 931/933)	Polypropylen / Polypropylene		Polyamid / Polyamide	
		Schraubenanzugs- moment (Nm) Screw tightening torque (Mn)	Rohrhaltekraft F (kN) Pipe shearing force F (kN)	Schraubenanzugs- moment (Nm) Screw tightening torque (Mn)	Rohrhaltekraft F (kN) Pipe shearing force F (kN)
1	M 6	5	0,9	6	0,9
2	M 8	12	2,1	12	2,2
3		12	1,9	12	2,0
4		12	2,7	12	2,9
5		8	1,7	8	2,5

Empfohlener Schellenabstand / Recommended clamp pitch

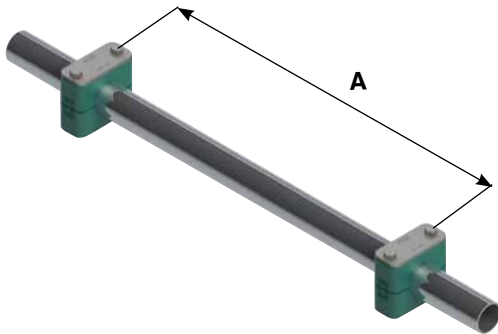

Die den entsprechenden Rohraußendurchmessern zugeordneten Schellenabstände sind Richtwerte für statische Belastung.

The clamp pitches assigned to the respective outside pipe diameters are standard values for static load.

Rohraußendurchmesser (mm) Outside pipe diameter (mm)	Schellenabstand A (m) Clamp pitch A (m)
6,0 – 12,7	1,0
12,7 – 22,0	1,2
22,0 – 32,0	1,5
32,0 – 38,0	2,0
38,0 – 57,0	2,7
57,0 – 75,0	3,0
75,0 – 76,1	3,5
76,1 – 88,9	3,7
88,9 – 102,0	4,0
102,0 – 114,0	4,5
114,0 – 168,0	5,0
168,0 – 219,0	6,0
219,0 – 324,0	6,7
324,0 – 356,0	7,0
356,0 – 406,0	7,5

Rohrbogenmontage / Pipe bend assembly



Rohrbögen sind unmittelbar vor und hinter dem Bogen mit RSB-Rohrschellen zu befestigen.

Pipe bends must be fixed with RSB-pipe clamps immediately in front of and behind the bend.

Rohrschellen Serie A

Tube clamps Series A



Abmessungen und Gewichte von Komplettschellen

Dimensions and weights of tube clamps, complete

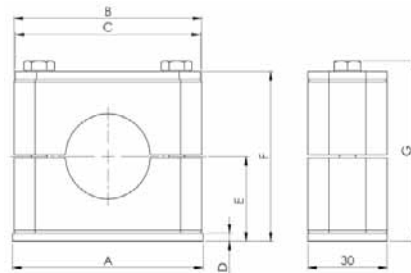

Größe Size	Abmessungen [mm] / Dimensions [mm]										Gewicht / 10 Stk. Weight / 10 Pcs. RAPR3-xxx [kg]
	A	B	C	D	E		F		G		
					Rippen Grooved	Glatt Smooth	Rippen Grooved	Glatt Smooth	Rippen Grooved	Glatt Smooth	
0	30	28	28	3	16,5	16,2	33	32,4	37	36,4	0,66
1	36	34	34	3	16,5	16,2	33	32,4	37	36,4	0,82
2	42	42	40	3	19,5	19,1	39	38,2	43	42,2	0,98
3	50	49	48	3	20,5	20	41	40	45	44	1,14
4	59	59	57	3	24	23,4	48	46,8	52	50,8	1,36
5	72	71	70	3	32	31,4	64	62,8	68	66,8	1,83
6	88	86	86	3	36	35,4	72	70,8	76	74,8	2,22
7	122	121	120	5	51,8	51	103,6	102	107,6	106	4,55
8	148	147	146	5	63,8	63	127,6	126	131,6	130	6,18

Das Gewicht wurde mit dem kleinsten Durchmesser (siehe Katalog) und der Standard-Ausführung der Stahlteile der jeweiligen Größe in losem Zustand ermittelt.

The weight was determined with the smallest diameter (see catalogue) and the standard model of the steel parts of the respective quantity in bulk.

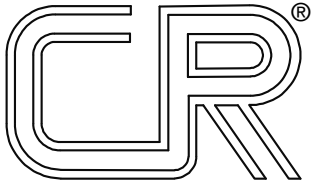

PP-CR®

Die Lösung für korrosionsgefährdete Anwendungen

PP-CR®

- the solution for susceptible to corrosion applications

Auf Grundlage des bewährten Polypropylens wurde das PP-CR entwickelt.
Ein spezieller Korrosions-Inhibitor verzögert effektiv die Bildung von Spaltkorrosion zwischen den Schellenkörpern und der Verrohrung.

Diese korrosionsverzögerten Eigenschaften wurden in Salzsprühnebeltests gemäß DIN EN ISO 9227 getestet und nachgewiesen.

Rohrschellen aus PP-CR sind in allen Standardbaugrößen unseres bewährten RSB-Rohrschellensystems erhältlich.

Rohrschellen aus PP-CR sind in der Farbe schiefergrau verfügbar.

*PP-CR has been developed based on our approved Polypropylene.
Crevice corrosion between the clamphalves and the tube is effectively retarded by a special corrosion inhibitor.*

These properties have been tested and successfully approved in a salt spray test according to DIN EN ISO 9227.

Tube Clamps made of PP-CR are available in all standard dimensions of our approved RSB-TUBE CLAMP range.

Tube Clamps made of PP-CR are available in slate gray colour.





Der Korrosionshemmer - Rohrschellen aus PP-CR®

The corrosion inhibitor

-Tube clamps made of PP-CR®

Schellengröße clamp size	Rohr-AD mm O.D. mm	1 Stück / 2 Schellenhälften 1 part / 2 clamp-halves
	d ₁	
1	4	RAPG RAPG-104/CR RAPG-106/CR RAPG-106,4/CR RAPG-108/CR RAPG-109,5/CR RAPG-110/CR RAPG-112/CR RAPG-112,7/CR
	6	
	6,4	
	8	
	9,5	
	10	
	12	
	12,7	
2	12,7	RAPG-212,7/CR RAPG-213,5/CR RAPG-214/CR RAPG-215/CR RAPG-216/CR RAPG-217,2/CR RAPG-218/CR
	13,5	
	14	
	15	
	16	
	17,2	
	18	
3	19	RAPG-319/CR RAPG-320/CR RAPG-321,3/CR RAPG-322/CR RAPG-323/CR RAPG-325/CR RAPG-325,4/CR
	20	
	21,3	
	22	
	23	
	25	
	25,4	
4	26,9	RAPG-426,9/CR RAPG-428/CR RAPG-430/CR
	28	
	30	
5	32	RAPG-532/CR RAPG-533,7/CR RAPG-535/CR RAPG-538/CR RAPG-540/CR RAPG-542/CR
	33,7	
	35	
	38	
	40	
	42	
6	44,5	RAPG-644,5/CR RAPG-645/CR RAPG-648/CR RAPG-650/CR RAPG-650,8/CR RAPG-652/CR RAPG-654/CR RAPG-655/CR RAPG-657/CR
	45	
	48	
	50	
	50,8	
	52	
	54	
	55	
	57	
7	57,2	RAPG-757,2/CR RAPG-760,3/CR RAPG-763,5/CR RAPG-770/CR RAPG-773/CR RAPG-776,1/CR
	60,3	
	63,5	
	70	
	73	
	76,1	
	8	
101,8		

Edelstahlrohr (1.4571) nach 4500 Std.
Salznebelprühtest

*Stainless steel tube (316ti) after 4500 h
salt spray test*

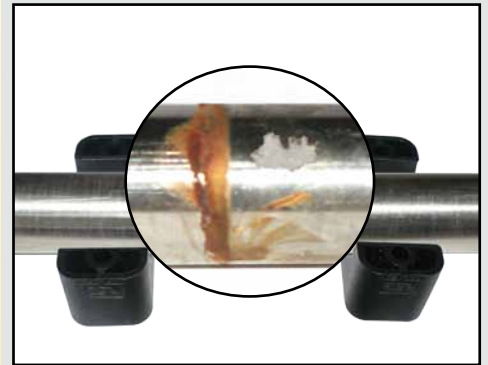

Resultat mit Standard-Polypropylene
Result with standard Polypropylene



Resultat mit PP-CR
Result with PP-CR

Vorteile

- Enorme Reduzierung von Spaltkorrosion
- Verlängerung der Wartungsintervalle
- Kostenersparnis durch deutlich längere Lebensdauer der Rohrsysteme

Advantages

- *Enormous reduction of crevice corrosion*
- *Extension of maintenance intervals*
- *cost reduction due to extended durability of the tubing*

Bestellzeichen

für Schellenhälften:

Polypropylen **RAPR**
innen glatt **RAPG²⁾**
Polyamid 6 **RANR**
innen glatt **RANG²⁾**
Vollgummi **RAVG²⁾ 3)**
Aluminium **RAAR¹⁾**

Bei Bedarf Standardkurzzeichen RAPR in der Spalte „Schellenhälften“ austauschen.

Order codes

for clamp-halves:

Polypropylene **RAPR**
inside smooth **RAPG²⁾**
Polyamide 6 **RANR**
inside smooth **RANG²⁾**
Rubber **RAVG²⁾ 3)**
Aluminium **RAAR¹⁾**

Replace standard abbreviation RAPR in column "clamp-halves" as required.

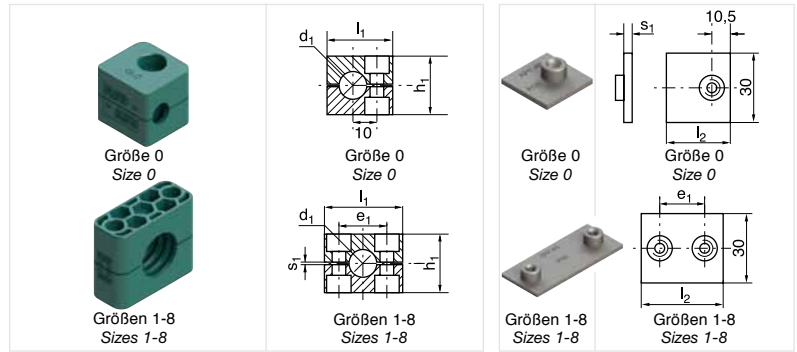

Schellengröße Clamp size	Rohr-AD mm O.D. mm	Rohr-NW Tube NB	Rohr-AD Zoll Inch O.D.	1 Stück / 2 Schellenhälften 1 part / 2 clamp-halves RAPR	2 Schellenhälften 2 clamp-halves RAPR-...				Anschweißplatte Weld plate APK-A			
					l ₁	h ₁	e ₁	s ₁	e ₁	l ₂	s ₁	
0	4	G 1/8	1/4 5/16 3/8	RAPR-004 RAPR-006 RAPR-006,4 RAPR-008 RAPR-009,5 RAPR-010 RAPR-012	28	27	-	0,6	APK-A 0	-	30	3
	6											
	6,4											
	8											
	9,5											
	10											
1	12	G 1/8	1/4 5/16 3/8	RAPR-104 RAPR-106 RAPR-106,4 RAPR-108 RAPR-109,5 RAPR-110 RAPR-112	34	27	20	0,6	APK-A 1	20	36	3
	4											
	6											
	6,4											
	8											
	9,5											
2	10	G 1/4	1/2 5/8	RAPR-212,7 RAPR-213,5 RAPR-214 RAPR-215 RAPR-216 RAPR-217,2 RAPR-218	42	33	26	0,8	APK-A 2	26	42	3
	12											
	12,7											
	13,5											
	14											
	15											
3	16	G 1/2	3/4 1	RAPR-319 RAPR-320 RAPR-321,3 RAPR-322 RAPR-323 RAPR-325 RAPR-325,4	49	35	33	1	APK-A 3	33	50	3
	17,2											
	18											
	19											
	20											
	21,3											
4	22	G 3/4	3/4 1	RAPR-426,9 RAPR-428 RAPR-430	59	42	40	1,2	APK-A 4	40	59	3
	23											
	25											
	25,4											
	26,9											
	28											
5	30	G 1	1 1/4 1 1/2	RAPR-532 RAPR-533,7 RAPR-535 RAPR-538 RAPR-540 RAPR-542	71	58	52	1,2	APK-A 5	52	72	3
	32											
	33,7											
	35											
	38											
	40											
6	42	G 1 1/4	1 3/4 2	RAPR-644,5 RAPR-645 RAPR-648 RAPR-650 RAPR-650,8 RAPR-652 RAPR-654 RAPR-655 RAPR-657	86	66	66	1,2	APK-A 6	66	88	3
	44,5											
	45											
	48											
	50											
	50,8											
7	52	G 1 1/2	2 1/4 2 1/2 2 3/4	RAPR-757,2 RAPR-760,3 RAPR-763,5 RAPR-770 RAPR-773 RAPR-776,1	121	93,6	94	1,6	APK-A 7	94	122	5
	54											
	55											
	57											
	57,2											
	60,3											
8	63,5	G 2	2 1/4 2 1/2 2 3/4	RAPR 888,9 RAPR 8101,8	147	117,6	120	1,6	APK-A 8	120	148	5
	70											
	73											
	76,1											
	88,9											
	101,8											
8	G 3 G 3 1/2	3 4	RAPR 888,9 RAPR 8101,8	147	117,6	120	1,6	APK-A 8	120	148	5	

Metallteile auch in Edelstahl lieferbar.

¹⁾Aluminium in Größen 0 bis 6 ²⁾ohne Vorspannung ³⁾Bei Montage von Vollgummi-Schellen sind Deckplatten, Sechskantschrauben und Sicherungsscheiben zu verwenden

All metal parts available in stainless steel.

¹⁾Aluminium sizes 0 to 6 ²⁾without prestress ³⁾When assembling solid rubber tube clamps, cover plates, hexagon screws and locking washers must be used



Komplett-Programm siehe Seiten 23 bis 27

Complete range please refer to pages 23 to 27

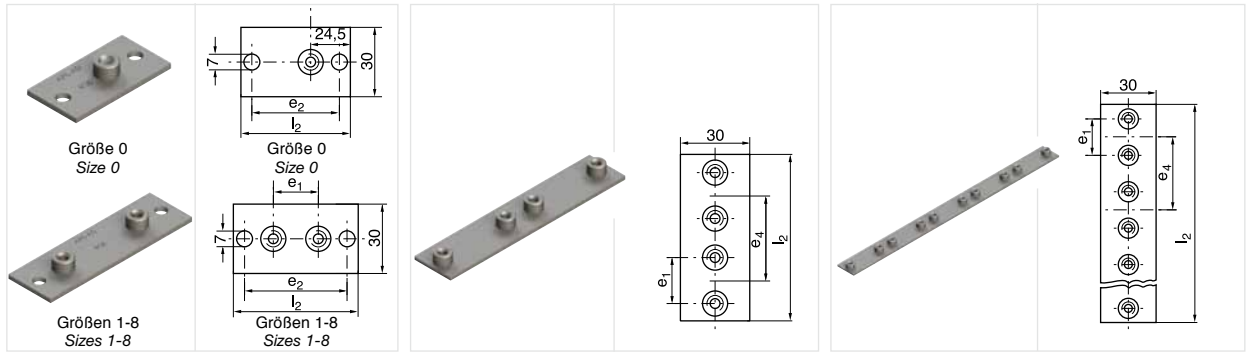

Schellengröße Clamp size	Anschweiß- und Schraubplatte, lang Weld- and screwplate, elongated APL-A	Anschweißplatte, doppelt Weld plate, double APD-A			Reihen-Anschweißplatte Multiple weld plate APR-A							
		e ₁	l ₂	e ₂	e ₁	e ₄	l ₂					
0	APL-A 0	–	58	44	APD-A 0	–	30	61	APR-A 0 10 Schellen / Clamps	–	30	298
1	APL-A 1	20	64	50	APD-A 1 APDL-A 1	20 20	35 40	69 76	APR-A 1 APRL-A 1 10 Schellen / Clamps	20 20	35 40	349 394
2	APL-A 2	26	70	56	APD-A 2 APDL-A 2	26 26	43 52	86 94	APR-A 2 APRL-A 2 10 Schellen / Clamps	26 26	43 52	427 508
3	APL-A 3	33	78	64	APD-A 3 APDL-A 3	33 33	52 75	104 125	APR-A 3 APRL-A 3 10 Schellen / Clamps	33 33	52 75	516 723
4	APL-A 4	40	87	73	APD-A 4	40	60	117	APR-A 4 5 Schellen / Clamps	40	60	297
5	APL-A 5	52	100	86	APD-A 5	52	75	145	APR-A 5 5 Schellen / Clamps	52	75	370
6	APL-A 6	66	116	100	APD-A 6	66	90	176	APR-A 6 5 Schellen / Clamps	66	90	446
7	APL-A 7	94	150	136								
8	APL-A 8	120	178	162								

Metalteile auch in Edelstahl lieferbar.
All metal parts available in stainless steel.



Komplett-Programm siehe Seiten 23 bis 27

Complete range please refer to pages 23to 27



Schellengröße Clamp size	Deckplatte Cover plate DP-A		Schlitzschraube Slotted head screw SL-A			Sechskantschraube Hexagon head screw SSL-A			Innensechskantschraube Hexagon socket head screw IS-A						
		l_3	e_1		d	x	l		d	x	l				
0	DP-A 0	-	-	SL-A 0 / A 1	M 6	x	20	SSL-A 0 / A 1	M 6	x	30	IS-A 0 / A 1	M 6	x	20
1	DP-A 1	34	20	SL-A 0 / A 1	M 6	x	20	SSL-A 0 / A 1	M 6	x	30	IS-A 0 / A 1	M 6	x	20
2	DP-A 2	40	26	SL-A 2	M 6	x	25	SSL-A 2 (SS-B 1)	M 6	x	35	IS-A 2	M 6	x	25
3	DP-A 3	48	33	SL-A 3	M 6	x	30	SSL-A 3	M 6	x	40	IS-A 3	M 6	x	30
4	DP-A 4	57	40	SL-A 4	M 6	x	35	SSL-A 4	M 6	x	45	IS-A 4 (IS-B 1)	M 6	x	35
5	DP-A 5	70	52	SL-A 5	M 6	x	50	SSL-A 5	M 6	x	60	IS-A 5	M 6	x	50
6	DP-A 6	86	66	SL-A 6	M 6	x	60	SSL-A 6	M 6	x	70	IS-A 6	M 6	x	60
7	DP-A 7	120	94	SL-A 7	M 6	x	90	SSL-A 7	M 6	x	100	IS-A 7	M 6	x	90
8	DP-A 8	146	120	SL-A 8	M 6	x	110	SSL-A 8	M 6	x	125	IS-A 8	M 6	x	110

Metallteile auch in Edelstahl lieferbar.
All metal parts available in stainless steel.



Komplett-Programm siehe Seiten 23 bis 27

Complete range please refer to pages 23 to 27

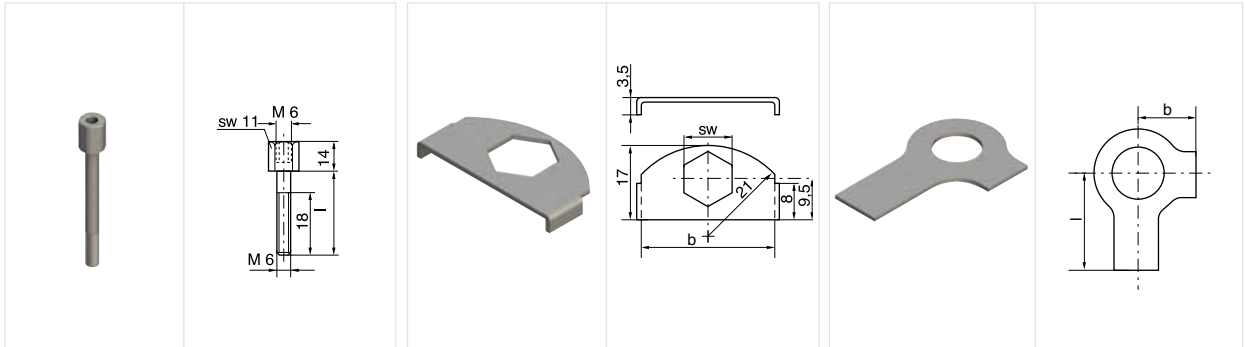

Schellengröße Clamp size	Aufbauschraube ¹⁾ Stacking bolt ¹⁾		Sicherungsblech ¹⁾ Locking plate ¹⁾			Sicherungsscheibe ²⁾ Locking washer ²⁾		
	AS-A	l	SBR-A	b	SW	US-A	b	l
0	AS-A 0 / A 1 (AS-B1)	20						
1	AS-A 0 / A 1 (AS-B1)	20						
2	AS-A 2	25						
3	AS-A 3	28						
4	AS-A 4	34	SBR-A	30	11	US-A	9	18
5	AS-A 5	50						
6	AS-A 6	60						
7	AS-A 7	85						
8	AS-A 8	110						

Metallteile auch in Edelstahl lieferbar.

¹⁾Für Einsatz von Aufbauschrauben bei Aufbaumontage sind Sicherungsbleche notwendig

²⁾Bei Montage von Vollgummi-Schellen sind Deckplatten, Sechskantschrauben und Sicherungsscheiben zu verwenden

All metal parts available in stainless steel.

¹⁾The usage of stacking bolts necessitates the use of locking plates during the construction assembly

²⁾When assembling solid rubber clamps, cover plates, hexagon screws and locking washers must be used



VISITEC

VISITEC

Die Schienenmutter mit Verlustsicherung.

The railnut with loss protection.

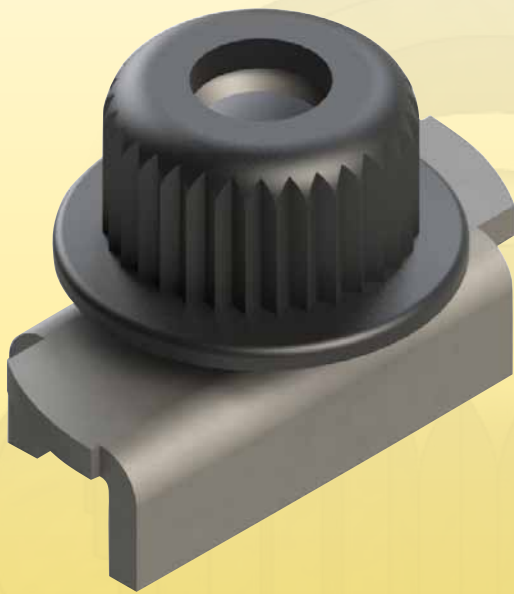

Vorteile

- 40% Zeitersparnis bei der Montage
- Schnelle und einfache Installation
- Schall- und vibrationsdämmend
- Optimal bei vertikaler Montage

Advantages

- 40% time savings during installation
- Fast and easy to install
- Vibration and sound insulating function
- Especially for vertical installations

Leichte Baureihe

Bestellbezeichnung:
TM-A/B1 VISITEC 1.4571
TM-A/B1 VISITEC CRVIF

Lieferbar in CR-VI freier Beschichtung und Edelstahl 1.4571.

*Light Series
Order Code:
TM-A/B1 VISITEC 1.4571
TM-A/B1 VISITEC CRVIF*

Available with CR-VI free coating and in stainless steel 1.4571

Das neue Design verhindert den Verlust der Gummikappe während der Installation. Der große Gummiflansch verhindert dass die Tragschienenmutter während der Montage in die Schiene fällt und hat zusätzlich eine schall- und vibrationsdämmende Funktion.

Die Gummikappe verfügt über eine integrierte Schraubensicherung. Schnelle und einfache Installation, einfach zu justieren auch bei vertikalen Installationen.

The big flange prevents that the railnut falls into the rail during installation and has a vibration and sound insulating function.

The rubbercap has an integrated screw locking device. Fast and easy to install, easy to adjust, especially for vertical installations.

SENSOR-SCHELLE SERIE A

Bestellzeichen für Schellenhälften:

Polypropylen	RAPS-540
Polyamid 6	RANS-540
Vollgummi	RAVS-540

SENSOR CLAMP SERIES A

Order codes for clamp-halves:

Polypropylene	RAPS-540
Polyamide 6	RANS-540
Rubber	RAVS-540

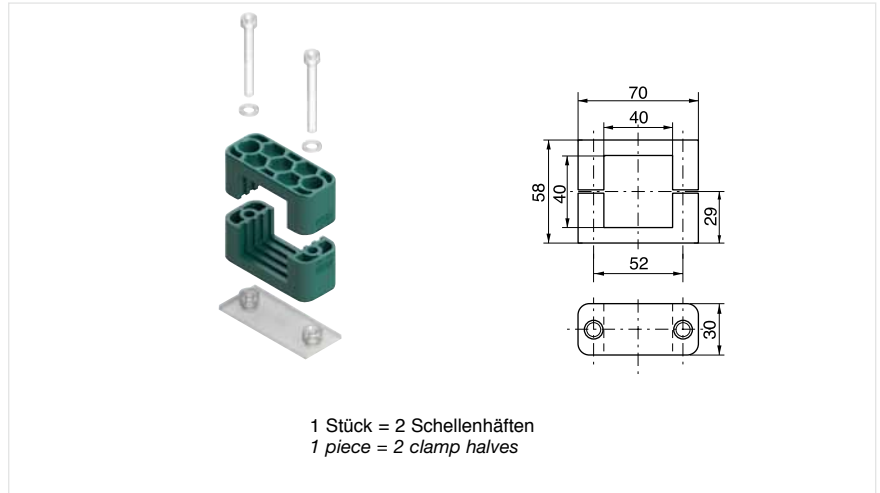

Befestigungsschelle für Näherungsschalter nach EN 50 025 und 50 037 mit quadratischem Gehäuse 40 x 40 mm.

Bei Montage auf Tragschienen können die Sensoren in axialer und seitlicher Richtung eingestellt werden.

Montagezubehör entsprechend Serie A, Größe 5.

Fixing clamp for proximity switch built to EN 50 025 and 50 037 with square casing 40 x 40 mm.

The sensors can be adjusted axially and laterally when mounted on mounting rails.

Accessory materials same as in Series A, size 5.



Für die Befestigung von Näherungsschalter mit zylindrischem Gehäuse nach EN 50 008, 50 036 und 50 040 oder ähnliche können Rohrschellen der Serie A mit entsprechendem Durchmesser verwendet werden.

Series A tube clamps of suitable diameter can be used for fixing proximity switches with a cylindrical casing built according to EN 50 008, 50 036 and 50 040 or similar.



Bestellzeichen

für Schellenhälften:

Polypropylen	RAPR
innen glatt	RAPG
Polyamid 6	RANR
innen glatt	RANG
Vollgummi	RAVG³⁾
Aluminium	RAAR

Bei Bedarf Standardkurzzeichen RAPR in der Spalte „Schellenhälften“ austauschen.

Order codes

for clamp-halves:

<i>Polypropylene</i>	RAPR
<i>inside smooth</i>	RAPG
<i>Polyamide 6</i>	RANR
<i>inside smooth</i>	RANG
<i>Rubber</i>	RAVG³⁾
<i>Aluminium</i>	RAAR

Replace standard abbreviation RAPR in column "clamp-halves" as required.

2 Schellenhälften mit Anschweißplatte, Schlitzschrauben und U-Scheiben
2 clamp halves with weld plate, slotted head screws and bushes



2 Schellenhälften mit Anschweißplatte, Innensechskantschrauben und U-Scheiben
2 clamp halves with weld plate, hexagon socket head screws and bushes



2 Schellenhälften mit Anschweißplatte, Deckplatte und Sechskantschrauben
2 clamp halves with weld plate, cover plate and hexagon head screws



Schellengröße Clamp size	Rohr-AD mm O.D. mm	Rohr-NW Tube NB	Rohr-AD Zoll Inch O.D.	Bestellzeichen Order Codes	Bestellzeichen Order Codes	Bestellzeichen Order Codes			
0 ¹⁾	4	G 1/8	1/4 5/16 3/8	RAPR 1-004	RAPR 2-004	RAPR 3-004			
	6			RAPR 1-006	RAPR 2-006	RAPR 3-006			
	6,4			RAPR 1-006,4	RAPR 2-006,4	RAPR 3-006,4			
	8			RAPR 1-008	RAPR 2-008	RAPR 3-008			
	9,5			RAPR 1-009,5	RAPR 2-009,5	RAPR 3-009,5			
	10			RAPR 1-010	RAPR 2-010	RAPR 3-010			
1	12	G 1/8	1/4 5/16 3/8	RAPR 1-012	RAPR 2-012	RAPR 3-012			
	4			RAPR 1-104	RAPR 2-104	RAPR 3-104			
	6			RAPR 1-106	RAPR 2-106	RAPR 3-106			
	6,4			RAPR 1-106,4	RAPR 2-106,4	RAPR 3-106,4			
	8			RAPR 1-108	RAPR 2-108	RAPR 3-108			
	9,5			RAPR 1-109,5	RAPR 2-109,5	RAPR 3-109,5			
2	10	G 3/8	1/2 5/8	RAPR 1-110	RAPR 2-110	RAPR 3-110			
	12			RAPR 1-112	RAPR 2-112	RAPR 3-112			
	12,7			G 1/4	1/2	RAPR 1-212,7	RAPR 2-212,7	RAPR 3-212,7	
	13,5					RAPR 1-213,5	RAPR 2-213,5	RAPR 3-213,5	
	14					RAPR 1-214	RAPR 2-214	RAPR 3-214	
	3			15	G 3/8	5/8	RAPR 1-215	RAPR 2-215	RAPR 3-215
16		RAPR 1-216	RAPR 2-216	RAPR 3-216					
17,2		RAPR 1-217,2	RAPR 2-217,2	RAPR 3-217,2					
18		RAPR 1-218	RAPR 2-218	RAPR 3-218					
19		G 1/2	3/4	RAPR 1-319			RAPR 2-319	RAPR 3-319	
20				RAPR 1-320			RAPR 2-320	RAPR 3-320	
21,3	RAPR 1-321,3			RAPR 2-321,3	RAPR 3-321,3				
22	RAPR 1-322			RAPR 2-322	RAPR 3-322				
23	RAPR 1-323			RAPR 2-323	RAPR 3-323				
25	RAPR 1-325			RAPR 2-325	RAPR 3-325				
4	25,4	G 3/4	1	RAPR 1-325,4	RAPR 2-325,4	RAPR 3-325,4			
	26,9			RAPR 1-426,9	RAPR 2-426,9	RAPR 3-426,9			
	28			RAPR 1-428	RAPR 2-428	RAPR 3-428			
	30			RAPR 1-430	RAPR 2-430	RAPR 3-430			
	32			G 1	1 1/4	RAPR 1-532	RAPR 2-532	RAPR 3-532	
	33,7					RAPR 1-533,7	RAPR 2-533,7	RAPR 3-533,7	
35	RAPR 1-535	RAPR 2-535	RAPR 3-535						
38	RAPR 1-538	RAPR 2-538	RAPR 3-538						
40	RAPR 1-540	RAPR 2-540	RAPR 3-540						
42	RAPR 1-542	RAPR 2-542	RAPR 3-542						
6	44,5	G 1 1/2	1 3/4 2	RAPR 1-644,5	RAPR 2-644,5	RAPR 3-644,5			
	45			RAPR 1-645	RAPR 2-645	RAPR 3-645			
	48			RAPR 1-648	RAPR 2-648	RAPR 3-648			
	50			RAPR 1-650	RAPR 2-650	RAPR 3-650			
	50,8			RAPR 1-650,8	RAPR 2-650,8	RAPR 3-650,8			
	52			RAPR 1-652	RAPR 2-652	RAPR 3-652			
	54			RAPR 1-654	RAPR 2-654	RAPR 3-654			
	55			RAPR 1-655	RAPR 2-655	RAPR 3-655			
	57			RAPR 1-657	RAPR 2-657	RAPR 3-657			
	7			57,2	G 2	2 1/4 2 1/2 2 3/4	RAPR 1-757,2	RAPR 2-757,2	RAPR 3-757,2
				60,3			RAPR 1-760,3	RAPR 2-760,3	RAPR 3-760,3
				63,5			RAPR 1-763,5	RAPR 2-763,5	RAPR 3-763,5
70		RAPR 1-770	RAPR 2-770	RAPR 3-770					
73		RAPR 1-773	RAPR 2-773	RAPR 3-773					
76,1		RAPR 1-776,1	RAPR 2-776,1	RAPR 3-776,1					
8	88,9	G 3	4	RAPR 1-888,9	RAPR 2-888,9	RAPR 3-888,9			
	101,8			RAPR 1-8101,8	RAPR 2-8101,8	RAPR 3-8101,8			

Werden andere Kombinationen benötigt, so bestellen Sie diese bitte in Einzelteilen (Bestellzeichen hierfür siehe Seiten 16 – 20). Die Auslieferung erfolgt unmontiert in Einzelteilen.

¹⁾Schellen der Größe 0 werden in Abweichung von den Abbildungen nur mit einer Schraube befestigt

³⁾Bei Montage von Vollgummi-Schellen sind Deckplatten, Sechskantschrauben und Sicherungsscheiben zu verwenden

If different combinations are required, we would be obliged if they could be ordered as separate components (Please refer to individual components, pages 16 – 20).

Delivery in unassembled individual components. ¹⁾Contrary to illustration size 0 clamps are secured by only one screw

³⁾When assembling solid rubber tube clamps, cover plates, hexagon screws and locking washers must be used

Bestellzeichen

für Schellenhälften:

Polypropylen	RAPR
innen glatt	RAPG
Polyamid 6	RANR
innen glatt	RANG
Vollgummi	RAVG³⁾
Aluminium	RAAR

Bei Bedarf Standardkurzzeichen RAPR in der Spalte „Schellenhälften“ austauschen.

Order codes

for clamp-halves:

<i>Polypropylene</i>	RAPR
<i>inside smooth</i>	RAPG
<i>Polyamide 6</i>	RANR
<i>inside smooth</i>	RANG
<i>Rubber</i>	RAVG³⁾
<i>Aluminium</i>	RAAR

Replace standard abbreviation RAPR in column "clamp-halves" as required.

2 Schellenhälften mit
Anschweiß/Anschraubplatte,
Schlitzschrauben und
U-Scheiben

2 clamp halves with weld/
screw plate, slotted head
screws and bushes



2 Schellenhälften mit
Anschweiß/Anschraubplatte,
Innensechskantschrauben und
U-Scheiben

2 clamp halves with weld/
screw plate, hexagon socket
head screws and
bushes



2 Schellenhälften mit
Anschweiß/Anschraubplatte,
Deckplatte und Sechskant-
schrauben

2 clamp halves with weld/
screw plate, cover plate
and hexagon
head screws



Schellengröße Clamp size	Rohr-AD mm O.D. mm	Rohr-NW Tube NB	Rohr-AD Zoll Inch O.D.	Bestellzeichen Order Codes	Bestellzeichen Order Codes	Bestellzeichen Order Codes		
0 ¹⁾	4	G 1/8	1/4 5/16 3/8	RAPR 4-004	RAPR 5-004	RAPR 6-004		
	6			RAPR 4-006	RAPR 5-006	RAPR 6-006		
	6,4			RAPR 4-006,4	RAPR 5-006,4	RAPR 6-006,4		
	8			RAPR 4-008	RAPR 5-008	RAPR 6-008		
	9,5			RAPR 4-009,5	RAPR 5-009,5	RAPR 6-009,5		
	10			RAPR 4-010	RAPR 5-010	RAPR 6-010		
1	12	G 1/8	1/4 5/16 3/8	RAPR 4-012	RAPR 5-012	RAPR 6-012		
	4			RAPR 4-104	RAPR 5-104	RAPR 6-104		
	6			RAPR 4-106	RAPR 5-106	RAPR 6-106		
	6,4			RAPR 4-106,4	RAPR 5-106,4	RAPR 6-106,4		
	8			RAPR 4-108	RAPR 5-108	RAPR 6-108		
	9,5			RAPR 4-109,5	RAPR 5-109,5	RAPR 6-109,5		
2	10	G 1/8	1/4 5/16 3/8	RAPR 4-110	RAPR 5-110	RAPR 6-110		
	12			RAPR 4-112	RAPR 5-112	RAPR 6-112		
	12,7			G 1/4	1/2	RAPR 4-212,7	RAPR 5-212,7	RAPR 6-212,7
	13,5					RAPR 4-213,5	RAPR 5-213,5	RAPR 6-213,5
	14					RAPR 4-214	RAPR 5-214	RAPR 6-214
	15			G 3/8	5/8	RAPR 4-215	RAPR 5-215	RAPR 6-215
16	RAPR 4-216	RAPR 5-216	RAPR 6-216					
17,2	RAPR 4-217,2	RAPR 5-217,2	RAPR 6-217,2					
3	18	G 3/8	5/8	RAPR 4-218	RAPR 5-218	RAPR 6-218		
	19			G 1/2	3/4	RAPR 4-319	RAPR 5-319	RAPR 6-319
	20					RAPR 4-320	RAPR 5-320	RAPR 6-320
	21,3					RAPR 4-321,3	RAPR 5-321,3	RAPR 6-321,3
	22					RAPR 4-322	RAPR 5-322	RAPR 6-322
	23					RAPR 4-323	RAPR 5-323	RAPR 6-323
25	1	1	RAPR 4-325			RAPR 5-325	RAPR 6-325	
25,4			RAPR 4-325,4	RAPR 5-325,4	RAPR 6-325,4			
4	26,9	G 3/4	1	RAPR 4-426,9	RAPR 5-426,9	RAPR 6-426,9		
	28			RAPR 4-428	RAPR 5-428	RAPR 6-428		
	30			RAPR 4-430	RAPR 5-430	RAPR 6-430		
5	32	G 1	1 1/4	RAPR 4-532	RAPR 5-532	RAPR 6-532		
	33,7			RAPR 4-533,7	RAPR 5-533,7	RAPR 6-533,7		
	35			RAPR 4-535	RAPR 5-535	RAPR 6-535		
	38	G 1 1/4	1 1/2	RAPR 4-538	RAPR 5-538	RAPR 6-538		
	40			RAPR 4-540	RAPR 5-540	RAPR 6-540		
	42			RAPR 4-542	RAPR 5-542	RAPR 6-542		
6	44,5	G 1 1/2	1 3/4	RAPR 4-644,5	RAPR 5-644,5	RAPR 6-644,5		
	45			RAPR 4-645	RAPR 5-645	RAPR 6-645		
	48			RAPR 4-648	RAPR 5-648	RAPR 6-648		
	50			RAPR 4-650	RAPR 5-650	RAPR 6-650		
	50,8			RAPR 4-650,8	RAPR 5-650,8	RAPR 6-650,8		
	52			RAPR 4-652	RAPR 5-652	RAPR 6-652		
	54			RAPR 4-654	RAPR 5-654	RAPR 6-654		
	55			RAPR 4-655	RAPR 5-655	RAPR 6-655		
	57			RAPR 4-657	RAPR 5-657	RAPR 6-657		
	7			57,2	G 2	2 1/4	RAPR 4-757,2	RAPR 5-757,2
60,3		RAPR 4-760,3	RAPR 5-760,3	RAPR 6-760,3				
63,5		RAPR 4-763,5	RAPR 5-763,5	RAPR 6-763,5				
70		RAPR 4-770	RAPR 5-770	RAPR 6-770				
73		RAPR 4-773	RAPR 5-773	RAPR 6-773				
76,1		G 2 1/2	3	RAPR 4-776,1			RAPR 5-776,1	RAPR 6-776,1
8	88,9	G 3	3 1/2	RAPR 4-888,9	RAPR 5-888,9	RAPR 6-888,9		
	101,8			RAPR 4-8101,8	RAPR 5-8101,8	RAPR 6-8101,8		

Werden andere Kombinationen benötigt, so bestellen Sie diese bitte in Einzelteilen (Bestellzeichen hierfür siehe Seiten 16 – 20). Die Auslieferung erfolgt unmontiert in Einzelteilen.

¹⁾Schellen der Größe 0 werden in Abweichung von den Abbildungen nur mit einer Schraube befestigt

³⁾Bei Montage von Vollgummi-Schellen sind Deckplatten, Sechskantschrauben und Sicherungsscheiben zu verwenden

If different combinations are required, we would be obliged if they could be ordered as separate components (Please refer to individual components, pages 16 – 20).

Delivery in unassembled individual components. ¹⁾Contrary to illustration size 0 clamps are secured by only one screw

³⁾When assembling solid rubber tube clamps, cover plates, hexagon screws and locking washers must be used

Bestellzeichen

für Schellenhälften:

Polypropylen	RAPR
innen glatt	RAPG
Polyamid 6	RANR
innen glatt	RANG
Vollgummi	RAVG³⁾
Aluminium	RAAR

Bei Bedarf Standardkurzzeichen RAPR in der Spalte „Schellenhälften“ austauschen.

Order codes

for clamp-halves:

<i>Polypropylene</i>	RAPR
<i>inside smooth</i>	RAPG
<i>Polyamide 6</i>	RANR
<i>inside smooth</i>	RANG
<i>Rubber</i>	RAVG³⁾
<i>Aluminium</i>	RAAR

Replace standard abbreviation RAPR in column "clamp-halves" as required.

2 Schellenhälften mit Tragschienen-Muttern, Schlitzschrauben und U-Scheiben

2 clamp halves with rail nuts, slotted head screws and bushes



2 Schellenhälften mit Tragschienen-Muttern, Innensechskantschrauben und U-Scheiben

2 clamp halves with rail nuts, socket head bolts and bushes



2 Schellenhälften mit Tragschienen-Muttern, Deckplatte und Sechskantschrauben

2 clamp halves with rail nuts, cover plate and hexagon head screws



Schellengröße Clamp size	Rohr-AD mm O.D. mm	Rohr-NW Tube NB	Rohr-AD Zoll Inch O.D.	Bestellzeichen Order Codes	Bestellzeichen Order Codes	Bestellzeichen Order Codes
0 ¹⁾	4	G 1/8	1/4 5/16 3/8	RAPR 9-004	RAPR 10-004	RAPR 12-004
	6			RAPR 9-006	RAPR 10-006	RAPR 12-006
	6,4			RAPR 9-006,4	RAPR 10-006,4	RAPR 12-006,4
	8			RAPR 9-008	RAPR 10-008	RAPR 12-008
	9,5			RAPR 9-009,5	RAPR 10-009,5	RAPR 12-009,5
1	10	G 1/8	1/4 5/16 3/8	RAPR 9-010	RAPR 10-010	RAPR 12-010
	12			RAPR 9-012	RAPR 10-012	RAPR 12-012
	4			RAPR 9-104	RAPR 10-104	RAPR 12-104
	6			RAPR 9-106	RAPR 10-106	RAPR 12-106
	6,4			RAPR 9-106,4	RAPR 10-106,4	RAPR 12-106,4
2	8	G 1/4	1/2 5/8	RAPR 9-108	RAPR 10-108	RAPR 12-108
	9,5			RAPR 9-109,5	RAPR 10-109,5	RAPR 12-109,5
	10			RAPR 9-110	RAPR 10-110	RAPR 12-110
	12			RAPR 9-112	RAPR 10-112	RAPR 12-112
	12,7			RAPR 9-212,7	RAPR 10-212,7	RAPR 12-212,7
3	13,5	G 3/8	5/8	RAPR 9-213,5	RAPR 10-213,5	RAPR 12-213,5
	14			RAPR 9-214	RAPR 10-214	RAPR 12-214
	15			RAPR 9-215	RAPR 10-215	RAPR 12-215
	16			RAPR 9-216	RAPR 10-216	RAPR 12-216
	17,2			RAPR 9-217,2	RAPR 10-217,2	RAPR 12-217,2
4	18	G 1/2	3/4	RAPR 9-218	RAPR 10-218	RAPR 12-218
	19			RAPR 9-319	RAPR 10-319	RAPR 12-319
	20			RAPR 9-320	RAPR 10-320	RAPR 12-320
	21,3			RAPR 9-321,3	RAPR 10-321,3	RAPR 12-321,3
	22			RAPR 9-322	RAPR 10-322	RAPR 12-322
5	23	G 3/4	1	RAPR 9-323	RAPR 10-323	RAPR 12-323
	25			RAPR 9-325	RAPR 10-325	RAPR 12-325
	25,4			RAPR 9-325,4	RAPR 10-325,4	RAPR 12-325,4
	26,9			RAPR 9-426,9	RAPR 10-426,9	RAPR 12-426,9
	28			RAPR 9-428	RAPR 10-428	RAPR 12-428
6	30	G 1	1 1/4	RAPR 9-430	RAPR 10-430	RAPR 12-430
	32			RAPR 9-532	RAPR 10-532	RAPR 12-532
	33,7			RAPR 9-533,7	RAPR 10-533,7	RAPR 12-533,7
	35			RAPR 9-535	RAPR 10-535	RAPR 12-535
	38			RAPR 9-538	RAPR 10-538	RAPR 12-538
7	40	G 1 1/4	1 1/2	RAPR 9-540	RAPR 10-540	RAPR 12-540
	42			RAPR 9-542	RAPR 10-542	RAPR 12-542
	44,5			RAPR 9-644,5	RAPR 10-644,5	RAPR 12-644,5
	45			RAPR 9-645	RAPR 10-645	RAPR 12-645
	48			RAPR 9-648	RAPR 10-648	RAPR 12-648
8	50	G 1 1/2	1 3/4	RAPR 9-650	RAPR 10-650	RAPR 12-650
	50,8			RAPR 9-650,8	RAPR 10-650,8	RAPR 12-650,8
	52			RAPR 9-652	RAPR 10-652	RAPR 12-652
	54			RAPR 9-654	RAPR 10-654	RAPR 12-654
	55			RAPR 9-655	RAPR 10-655	RAPR 12-655
9	57	G 2	2	RAPR 9-657	RAPR 10-657	RAPR 12-657
	57,2			RAPR 9-757,2	RAPR 10-757,2	RAPR 12-757,2
	60,3			RAPR 9-760,3	RAPR 10-760,3	RAPR 12-760,3
	63,5			RAPR 9-763,5	RAPR 10-763,5	RAPR 12-763,5
	70			RAPR 9-770	RAPR 10-770	RAPR 12-770
10	73	G 2 1/2	3	RAPR 9-773	RAPR 10-773	RAPR 12-773
	76,1			RAPR 9-776,1	RAPR 10-776,1	RAPR 12-776,1
	88,9			RAPR 9-888,9	RAPR 10-888,9	RAPR 12-888,9
	101,8			RAPR 9-8101,8	RAPR 10-8101,8	RAPR 12-8101,8

Werden andere Kombinationen benötigt, so bestellen Sie diese bitte in Einzelteilen (Bestellzeichen hierfür siehe Seiten 16 – 20). Die Auslieferung erfolgt unmontiert in Einzelteilen.

¹⁾Schellen der Größe 0 werden in Abweichung von den Abbildungen nur mit einer Schraube befestigt

³⁾Bei Montage von Vollgummi-Schellen sind Deckplatten, Sechskantschrauben und Sicherungsscheiben zu verwenden

If different combinations are required, we would be obliged if they could be ordered as separate components (Please refer to individual components, pages 16 – 20).

Delivery in unassembled individual components. ¹⁾Contrary to illustration size 0 clamps are secured by only one screw

³⁾When assembling solid rubber tube clamps, cover plates, hexagon screws and locking washers must be used

Bestellzeichen

für Schellenhälften:

Polypropylen	RAPR
innen glatt	RAPG
Polyamid 6	RANR
innen glatt	RANG
Vollgummi	RAVG³⁾
Aluminium	RAAR

Bei Bedarf Standardkurzzeichen RAPR in der Spalte „Schellenhälften“ austauschen.

Order codes

for clamp-halves:

Polypropylene	RAPR
inside smooth	RAPG
Polyamide 6	RANR
inside smooth	RANG
Rubber	RAVG³⁾
Aluminium	RAAR

Replace standard abbreviation RAPR in column "clamp-halves" as required.

2 Schellenhälften mit Schlitzschrauben und U-Scheiben
2 clamp halves, slotted head screws and bushes



2 Schellenhälften mit Innensechskantschrauben und U-Scheiben
2 clamp halves, hexagon socket head screws and bushes



Schellengröße Clamp size	Rohr-AD mm O.D. mm	Rohr-NW Tube NB	Rohr-AD Zoll Inch O.D.	Bestellzeichen Order Codes	Bestellzeichen Order Codes		
0 ¹⁾	4	G 1/8	1/4 5/16 3/8	RAPR 13-004	RAPR 14-004		
	6			RAPR 13-006	RAPR 14-006		
	6,4			RAPR 13-006,4	RAPR 14-006,4		
	8			RAPR 13-008	RAPR 14-008		
	9,5			RAPR 13-009,5	RAPR 14-009,5		
	10			RAPR 13-010	RAPR 14-010		
1	12	G 1/8	1/4 5/16 3/8	RAPR 13-012	RAPR 14-012		
	4			RAPR 13-104	RAPR 14-104		
	6			RAPR 13-106	RAPR 14-106		
	6,4			RAPR 13-106,4	RAPR 14-106,4		
	8			RAPR 13-108	RAPR 14-108		
	9,5			RAPR 13-109,5	RAPR 14-109,5		
2	10	G 1/8	1/4 5/16 3/8	RAPR 13-110	RAPR 14-110		
	12			RAPR 13-112	RAPR 14-112		
	12,7			G 1/4	1/2	RAPR 13-212,7	RAPR 14-212,7
	13,5					RAPR 13-213,5	RAPR 14-213,5
	14					RAPR 13-214	RAPR 14-214
	15			G 3/8	5/8	RAPR 13-215	RAPR 14-215
16	RAPR 13-216	RAPR 14-216					
17,2	RAPR 13-217,2	RAPR 14-217,2					
18			RAPR 13-218	RAPR 14-218			
3	19	G 1/2	3/4	RAPR 13-319	RAPR 14-319		
	20			RAPR 13-320	RAPR 14-320		
	21,3			RAPR 13-321,3	RAPR 14-321,3		
	22			RAPR 13-322	RAPR 14-322		
	23			RAPR 13-323	RAPR 14-323		
	25			RAPR 13-325	RAPR 14-325		
25,4	1	RAPR 13-325,4	RAPR 14-325,4				
4	26,9	G 3/4	1	RAPR 13-426,9	RAPR 14-426,9		
	28			RAPR 13-428	RAPR 14-428		
	30			RAPR 13-430	RAPR 14-430		
5	32	G 1	1 1/4	RAPR 13-532	RAPR 14-532		
	33,7			RAPR 13-533,7	RAPR 14-533,7		
	35			RAPR 13-535	RAPR 14-535		
	38			RAPR 13-538	RAPR 14-538		
	40			G 1 1/4	1 1/2	RAPR 13-540	RAPR 14-540
42	RAPR 13-542	RAPR 14-542					
6	44,5	G 1 1/2	1 3/4	RAPR 13-644,5	RAPR 14-644,5		
	45			RAPR 13-645	RAPR 14-645		
	48			RAPR 13-648	RAPR 14-648		
	50			RAPR 13-650	RAPR 14-650		
	50,8			2	RAPR 13-650,8	RAPR 14-650,8	
	52				RAPR 13-652	RAPR 14-652	
	54				RAPR 13-654	RAPR 14-654	
	55				RAPR 13-655	RAPR 14-655	
	57				RAPR 13-657	RAPR 14-657	
7	57,2	G 2	2 1/4	RAPR 13-757,2	RAPR 14-757,2		
	60,3			RAPR 13-760,3	RAPR 14-760,3		
	63,5			RAPR 13-763,5	RAPR 14-763,5		
	70			2 3/4	RAPR 13-770	RAPR 14-770	
	73				RAPR 13-773	RAPR 14-773	
	76,1				RAPR 13-776,1	RAPR 14-776,1	
8	88,9	G 3	3 1/2	RAPR 13-888,9	RAPR 14-888,9		
	101,8			RAPR 13-8101,8	RAPR 14-8101,8		

Werden andere Kombinationen benötigt, so bestellen Sie diese bitte in Einzelteilen (Bestellzeichen hierfür siehe Seiten 16 – 20). Die Auslieferung erfolgt unmontiert in Einzelteilen.

¹⁾Schellen der Größe 0 werden in Abweichung von den Abbildungen nur mit einer Schraube befestigt

³⁾Bei Montage von Vollgummi-Schellen sind Deckplatten, Sechskantschrauben und Sicherungsscheiben zu verwenden

If different combinations are required, we would be obliged if they could be ordered as separate components (Please refer to individual components, pages 16 – 20).

Delivery in unassembled individual components. ¹⁾Contrary to illustration size 0 clamps are secured by only one screw

³⁾When assembling solid rubber tube clamps, cover plates, hexagon screws and locking washers must be used

Bestellzeichen

für Schellenhälften:

Polypropylen	RAPR
innen glatt	RAPG
Polyamid 6	RANR
innen glatt	RANG
Vollgummi	RAVG³⁾
Aluminium	RAAR

Bei Bedarf Standardkurzzeichen RAPR in der Spalte „Schellenhälften“ austauschen.

Order codes

for clamp-halves:

<i>Polypropylene</i>	RAPR
<i>inside smooth</i>	RAPG
<i>Polyamide 6</i>	RANR
<i>inside smooth</i>	RANG
<i>Rubber</i>	RAVG³⁾
<i>Aluminium</i>	RAAR

Replace standard abbreviation RAPR in column "clamp-halves" as required.

2 Schellenhälften mit Deckplatte und Sechskantschrauben
2 clamp halves, cover plate and hexagon head screws



2 Schellenhälften mit Aufbauschrauben und Sicherungsblechen
2 clamp halves, stacking bolts and locking plates



Schellengröße Clamp size	Rohr-AD mm O.D. mm	Rohr-NW Tube NB	Rohr-AD Zoll Inch O.D.	Bestellzeichen Order Codes	Bestellzeichen Order Codes
0 ¹⁾	4	G 1/8	5/16	RAPR 16-004	RAPR 18-004
	6			RAPR 16-006	RAPR 18-006
	6,4			RAPR 16-006,4	RAPR 18-006,4
	8			RAPR 16-008	RAPR 18-008
	9,5			RAPR 16-009,5	RAPR 18-009,5
	10			RAPR 16-010	RAPR 18-010
1	12	G 1/8	5/16	RAPR 16-012	RAPR 18-012
	4			RAPR 16-104	RAPR 18-104
	6			RAPR 16-106	RAPR 18-106
	6,4			RAPR 16-106,4	RAPR 18-106,4
	8			RAPR 16-108	RAPR 18-108
	9,5			RAPR 16-109,5	RAPR 18-109,5
2	10	G 3/8	5/8	RAPR 16-110	RAPR 18-110
	12			RAPR 16-112	RAPR 18-112
	12,7			RAPR 16-212,7	RAPR 18-212,7
	13,5			RAPR 16-213,5	RAPR 18-213,5
	14			RAPR 16-214	RAPR 18-214
	15			RAPR 16-215	RAPR 18-215
3	16	G 1/2	1	RAPR 16-216	RAPR 18-216
	17,2			RAPR 16-217,2	RAPR 18-217,2
	18			RAPR 16-218	RAPR 18-218
	19			RAPR 16-319	RAPR 18-319
	20			RAPR 16-320	RAPR 18-320
	21,3			RAPR 16-321,3	RAPR 18-321,3
4	22	G 3/4	1	RAPR 16-322	RAPR 18-322
	23			RAPR 16-323	RAPR 18-323
	25			RAPR 16-325	RAPR 18-325
	25,4			RAPR 16-325,4	RAPR 18-325,4
	26,9			RAPR 16-426,9	RAPR 18-426,9
	28			RAPR 16-428	RAPR 18-428
5	30	G 1	1 1/4	RAPR 16-430	RAPR 18-430
	32			RAPR 16-532	RAPR 18-532
	33,7			RAPR 16-533,7	RAPR 18-533,7
	35			RAPR 16-535	RAPR 18-535
	38			RAPR 16-538	RAPR 18-538
	40			RAPR 16-540	RAPR 18-540
6	42	G 1 1/4	2	RAPR 16-542	RAPR 18-542
	44,5			RAPR 16-644,5	RAPR 18-644,5
	45			RAPR 16-645	RAPR 18-645
	48			RAPR 16-648	RAPR 18-648
	50			RAPR 16-650	RAPR 18-650
	50,8			RAPR 16-650,8	RAPR 18-650,8
	52			RAPR 16-652	RAPR 18-652
	54			RAPR 16-654	RAPR 18-654
	55			RAPR 16-655	RAPR 18-655
	57			RAPR 16-657	RAPR 18-657
7	57,2	G 2	2 1/4	RAPR 16-757,2	RAPR 18-757,2
	60,3			RAPR 16-760,3	RAPR 18-760,3
	63,5			RAPR 16-763,5	RAPR 18-763,5
	70			RAPR 16-770	RAPR 18-770
	73			RAPR 16-773	RAPR 18-773
	76,1			RAPR 16-776,1	RAPR 18-776,1
8	88,9	G 3	3 1/2	RAPR 16-888,9	RAPR 18-888,9
	101,8			RAPR 16-8101,8	RAPR 18-8101,8

Werden andere Kombinationen benötigt, so bestellen Sie diese bitte in Einzelteilen (Bestellzeichen hierfür siehe Seiten 16 – 20). Die Auslieferung erfolgt unmontiert in Einzelteilen.

¹⁾Schellen der Größe 0 werden in Abweichung von den Abbildungen nur mit einer Schraube befestigt

³⁾Bei Montage von Vollgummi-Schellen sind Deckplatten, Sechskantschrauben und Sicherungsscheiben zu verwenden

If different combinations are required, we would be obliged if they could be ordered as separate components (Please refer to individual components, pages 16 – 20).

Delivery in unassembled individual tube components. ¹⁾Contrary to illustration size 0 clamps are secured by only one screw

³⁾When assembling solid rubber tube clamps, cover plates, hexagon screws and locking washers must be used

2+5 ... das System!

Nur 2 Rohrschellengrößen

2+5 ... the system!

Only 2 tube clamp sizes



Mit unserem 2+5 RSB-Rohrschellen-System werden mit nur 2 Baugrößen die Rohrdurchmesser 6 – 42 mm abgedeckt.

- leichte Montage, kombinierbar mit allen Ausführungen
- alle Metallteile können aus unserem Standardprogramm der DIN 3015 verwendet werden

With our 2+5 RSB-Tube clamps system you can fix all tube diameters between 6 and 42 mm with only 2 tube clamp sizes.

- easy assembly, can be combined with all versions
- all metal parts of our standard program according to DIN 3015 can be used

Nur eine Reihen-Anschweißplatte mit gleichmäßigen Bolzenabständen für alle Rohrschellen der Größe 2+5

Only one multiple weldplate with similar weldnut distances suits all tube clamps of size 2+5



Bestellzeichen

für Schellenhälften:

Polypropylen
innen glatt
Polyamid 6
innen glatt
Vollgummi

RAPR
RAPG²⁾
RANR
RANG²⁾
RAVG^{2) 3)}

Order codes

for clamp-halves:

Polypropylene
inside smooth
Polyamide 6
inside smooth
Rubber

RAPR
RAPG²⁾
RANR
RANG²⁾
RAVG^{2) 3)}

Bei Bedarf Standardkurzzeichen RAPR in der Spalte „Schellenhälften“ austauschen.

Replace standard abbreviation RAPR in column "clamp-halves" as required.

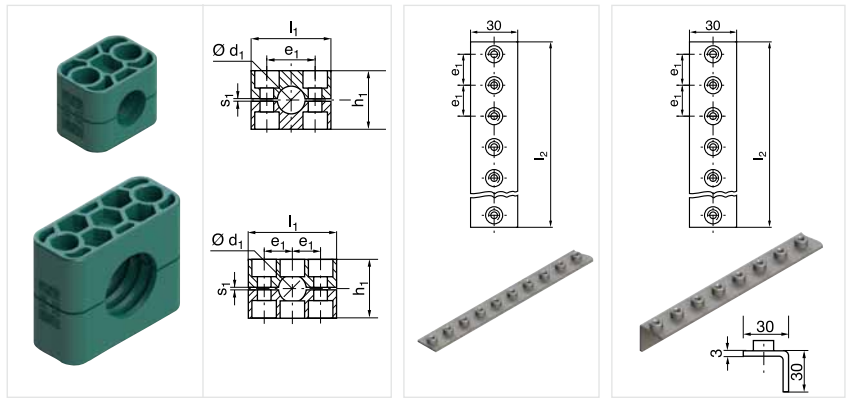

Schellengröße Clamp size	Rohr-AD mm O.D. mm	Rohr-NW Tube NB	Rohr-AD Zoll Inch O.D.	1 St. / 2 Schellenhälften 1 part / 2 clamp-halves RAPR	2 Schellenhälften 2 clamp-halves RAPR-...				Reihen-Anschweißplatte Multiple welding plate APRL-A 2		Winkel-Anschweißplatte Multiple welding plate, angled APRWL-A 2	
					l_1	h_1	e_1	s_1	e_1	l_2	e_1	l_2
2	6			RAPR-206								
	6,4		1/4	RAPR-206,4								
	8		5/16	RAPR-208								
	9,5		3/8	RAPR-209,5								
	10	G 1/8		RAPR-210								
	12			RAPR-212								
	12,7			RAPR-212,7	42	33	26	0,8				
	13,5	G 1/4		RAPR-213,5								
	14			RAPR-214								
	15			RAPR-215								
	16			RAPR-216								
	17,2	G 3/8		RAPR-217,2								
18			RAPR-218									
5	19		3/4	RAPR-519					26	508	26	508
	20			RAPR-520					20 Bolzen/Nuts		20 Bolzen/Nuts	
	21,3	G 1/2		RAPR-521,3								
	22			RAPR-522								
	23			RAPR-523								
	25			RAPR-525								
	25,4		1	RAPR-525,4								
	26,9	G 3/4		RAPR-526,9								
	28			RAPR-528	71	58	52	1,2				
	30			RAPR-530								
	32			RAPR-532								
	33,7	G 1		RAPR-533,7								
	35			RAPR-535								
	38			RAPR-538								
40			RAPR-540									
42	G 1 1/4		RAPR-542									

Metallteile auch in Edelstahl lieferbar. Einzelteile hierfür siehe Seite 16-20.

²⁾ohne Vorspannung

³⁾Bei Montage von Vollgummi-Schellen sind Deckplatten, Sechskantschrauben und Sicherungsscheiben zu verwenden

All metal parts available in stainless steel. Please refer to individual components pages 16-20.

²⁾without prestress

³⁾When assembling solid rubber tube clamps, cover plates, hexagon screws and locking washers must be used



Sonderschellen

Individuelle Lösungen nach Maß
 Stahl, Aluminium, Polyamid, Polypropylen,
 Vollgummi, Edelstahl ...

Special clamps

Custom-built to order
 steel, aluminium, polyamide, polypropylene,
 thermoplastic caoutchouc, stainless steel ...

RSB-Sonderschellen

lösen Ihr Befestigungsproblem dort,
 wo Serienteile überfordert sind.

Modernste Technologie ermöglicht uns
 eine flexible Umsetzung für
 Ihren Anwendungsfall.

Wir fertigen nach Kundenzeichnung
 oder in Kooperation mit Ihnen,
 wir beraten Sie fachmännisch,
 oder stehen Ihnen mit hauselgenen
 Entwicklungen zur Seite.

Sprechen Sie mit uns!

RSB-Special clamps

*For securing the parts that series
 components cannot.*

*State-of-the-art technology ensures
 that we can adapt to meet your
 individual requirements.*

*We work from a customer sketch
 or in cooperation with you. We offer
 expert advice or support you with
 our in-house developments.*

**We are the people
 to talk to!**



Rohrschellen Serie B

Tube clamps Series B

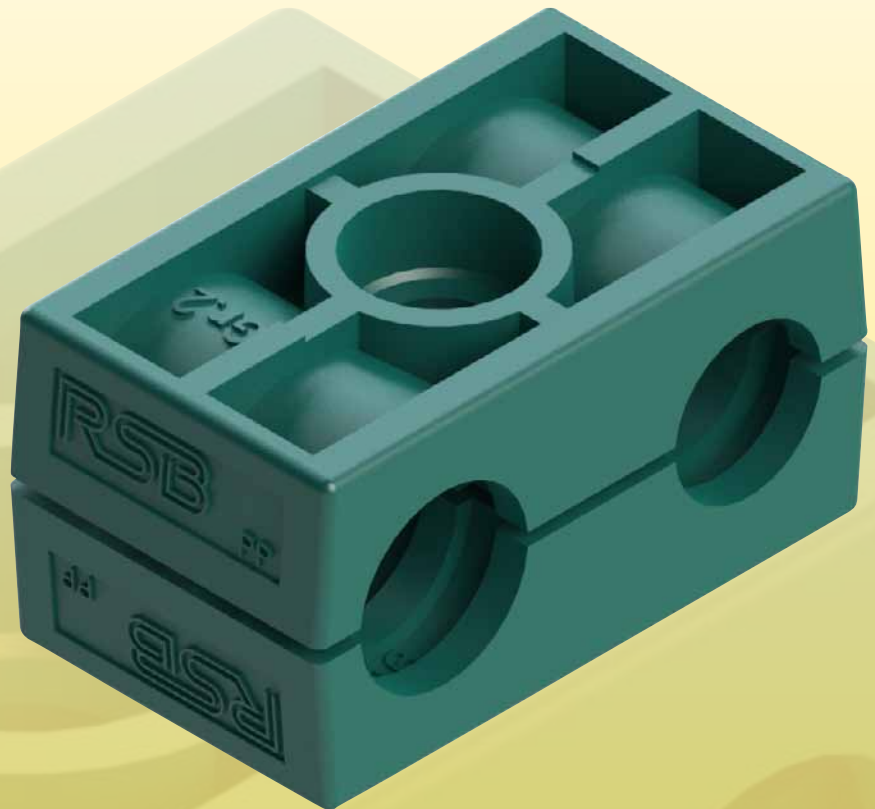

Abmessungen und Gewichte von Komplettschellen

Dimensions and weights of tube clamps, complete

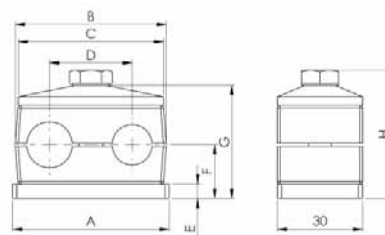

Größe Size	Abmessungen [mm] / Dimensions [mm]										Gewicht / 10 Stk. Weight / 10 Pcs. RBPR1-xxx [kg]	
	A	B	C	D	E	F		G		H		
						Rippen Grooved	Glatt Smooth	Rippen Grooved	Glatt Smooth	Rippen Grooved	Glatt Smooth	
1	37	36	34	20	3	16,5	16	37	36	41	40	0,74
2	55	53	51	29	5	18,7	18,1	39,4	38,2	44,7	43,5	1,32
3	70	67	64	36	5	23,5	22,7	49	47,4	54,3	52,7	1,73
4	85	82	78	45	5	26	25	54	52	59,3	57,3	2,13
5	110	106	102	56	5	32	31	66	64	71,3	69,3	3,01

Das Gewicht wurde mit dem kleinsten Durchmesser (siehe Katalog) und der Standard-Ausführung der Stahlteile der jeweiligen Größe in losem Zustand ermittelt.

The weight was determined with the smallest diameter (see catalogue) and the standard model of the steel parts of the respective quantity in bulk.

**Bestellzeichen
für Schellenhälften:**

Polypropylen **RBPR**
innen glatt **RBPG²⁾**
Polyamid 6 **RBNR**
innen glatt **RBNG²⁾**
Vollgummi **RBVG^{2) 3)}**

Bei Bedarf Standardkurz-
zeichen RBPR in der Spalte
„Schellenhälften“ austauschen.

**Order codes
for clamp-halves:**

Polypropylene **RBPR**
inside smooth **RBPG²⁾**
Polyamide 6 **RBNR**
inside smooth **RBNG²⁾**
Rubber **RBVG^{2) 3)}**

Replace standard abbreviation
RBPR in column "clamp-halves"
as required.

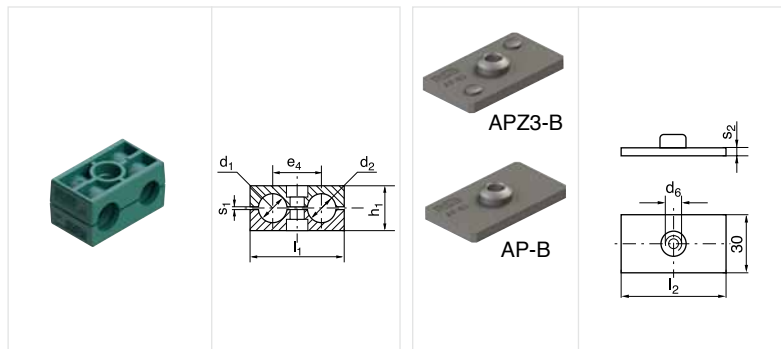

Schellengröße Clamp size	Rohr-AD mm O.D. mm	Rohr-NW Tube NB	Rohr-AD Zoll Inch O.D.	1 St. / 2 Schellenhälften ¹⁾ 1 part / 2 clamp-halves ¹⁾	2 Schellenhälften 2 clamp-halves				Anschweißplatte Weld plate	Anschweißplatte mit Verdrehsicherung Weld plate with locking device		
				RBPR	RBPR-...				AP-B	APZ3-B		
	d ₁ /d ₂				l ₁	h ₁	e ₄	s ₁		l ₂	s ₂	d ₆
1	6	G 1/8	1/4	RBPR-106	36	27	20	1,0	AP-B 1 APZ3-B 1 mit Verdrehsicherung with locking device	37	3	M 6
	6,4			RBPR-106,4								
	8			RBPR-108								
	9,5			RBPR-109,5								
	10			RBPR-110								
	12			RBPR-112								
2	12,7	G 1/4	1/2	RBPR-212,7	53	27,4	29	1,2	AP-B 2 APZ3-B 2 mit Verdrehsicherung with locking device	55	5	M 8
	13,5			RBPR-213,5								
	14			RBPR-214								
	15			RBPR-215								
	16			RBPR-216								
	17,2			RBPR-217,2								
18	RBPR-218											
3	19	G 1/2	3/4	RBPR-319	67	37	36	1,6	AP-B 3 APZ3-B 3 mit Verdrehsicherung with locking device	70	5	M 8
	20			RBPR-320								
	21,3			RBPR-321,3								
	22			RBPR-322								
	25			RBPR-325								
	25,4			RBPR-325,4								
4	26,9	G 3/4	1	RBPR-426,9	82	42	45	2	AP-B 4 APZ3-B 4 mit Verdrehsicherung with locking device	85	5	M 8
	28			RBPR-428								
	30			RBPR-430								
5	32	G 1	1 1/4	RBPR-532	106	54	56	2	AP-B 5 APZ3-B 5 mit Verdrehsicherung with locking device	110	5	M 8
	33,7			RBPR-533,7								
	35			RBPR-535								
	38			RBPR-538								
	40			RBPR-540								
	42			RBPR-542								

Metallteile in Edelstahl lieferbar.

All metal parts available in stainless steel.

¹⁾Zweirohrschellen mit unterschiedlichen Rohr-AD auf Anfrage ²⁾ohne Vorspannung

³⁾Bei Montage von Vollgummi-Schellen sind Deckplatten, Sechskantschrauben und Sicherungsscheiben zu verwenden

¹⁾Twin-tube clamps with different outer tube diameter upon request ²⁾without prestress

³⁾When assembling solid rubber tube clamps, cover plates, hexagon screws and locking washers must be used



Komplett-Programm siehe Seiten 36 und 37

Complete range please refer to pages 36 to 37

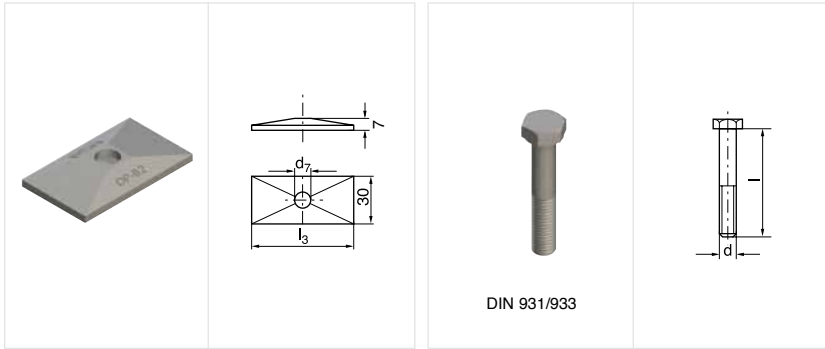

Schellengröße Clamp size	Deckplatte Cover plate		Sechskantschraube Hexagon head screw				
	DP-B	l ₃	d ₇	SS-B	d	x	l
1	DP-B 1	34	7	SS-B 1 (SSL-A 2)	M 6	x	35
2	DP-B 2	51	9	SS-B 2	M 8	x	35
3	DP-B 3	64	9	SS-B 3	M 8	x	45
4	DP-B 4	78	9	SS-B 4	M 8	x	50
5	DP-B 5	102	9	SS-B 5	M 8	x	60

Metallteile in Edelstahl lieferbar.
All metal parts available in stainless steel.



Komplett-Programm siehe Seiten 36 und 37

Complete range please refer to pages 36 to 37

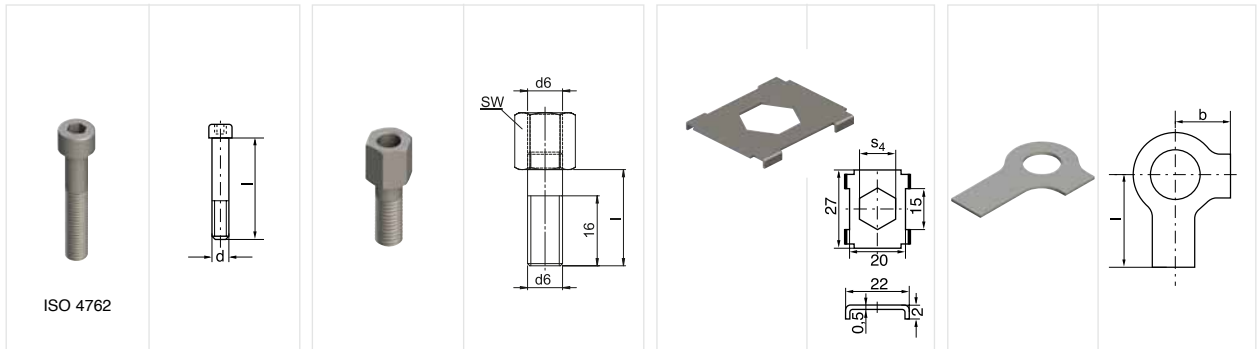

Schellengröße Clamp size	Innensechskantschraube Hexagon socket head screw IS-B	Aufbauschraube ¹⁾ Stacking bolt ¹⁾ AS-B			Sicherungsblech ¹⁾ Locking plate ¹⁾ SB-B		Sicherungsscheibe ²⁾ Locking washer ²⁾ US						
		d	x	l	l	d ₆	sw	s ₄	b	l			
1	IS-B 1 (IS-A 4)	M 6	x	35	AS-B 1 (AS-A 0/A 1)	20	M 6	11	SB-B 1	11	US-A	9	18
2	IS-B 2	M 8	x	35	AS-B 2	22	M 8	12					
3	IS-B 3	M 8	x	45	AS-B 3	30	M 8	12	SB-B 2	12	US-B 2	11	20
4	IS-B 4	M 8	x	50	AS-B 4	35	M 8	12					
5	IS-B 5	M 8	x	60	AS-B 5	47	M 8	12					

Metallteile auch in Edelstahl lieferbar.

¹⁾Für den Einsatz von Aufbauschrauben bei Aufbaumontage sind Sicherungsbleche notwendig

²⁾Bei Montage von Vollgummi-Schellen sind Deckplatten, Sechskantschrauben und Sicherungsscheiben zu verwenden

All metal parts available in stainless steel.

¹⁾The usage of stacking bolts necessitates the deployment of locking plates during the construction assembly

²⁾When assembling solid rubber clamps, cover plates, hexagon screws and locking washers must be used



Bestellzeichen

für Schellenhälften:

Polypropylen	RBPR
innen glatt	RBPG
Polyamid 6	RBNR
innen glatt	RBNG
Vollgummi	RBVG³⁾

Bei Bedarf Standardkurzzeichen RBPR in der Spalte „Bestellzeichen“ austauschen.

Order codes

for clamp-halves:

<i>Polypropylene</i>	RBPR
<i>inside smooth</i>	RBPG
<i>Polyamide 6</i>	RBNR
<i>inside smooth</i>	RBNG
<i>Rubber</i>	RBVG³⁾

Replace standard abbreviation RBPR in column "Order codes" as required.

2 Schellenhälften mit Anschweißplatte, Deckplatte und Sechskantschraube

2 clamp halves with weld plate, cover plate and hexagon head screw



2 Schellenhälften mit Anschweißplatte, Deckplatte und Innensechskantschraube

2 clamp halves with weld plate, cover plate and hexagon socket head screw



2 Schellenhälften mit Tragschienen-Mutter, Deckplatte und Sechskantschraube

2 clamp halves with rail nut, cover plate and hexagon head screw



Schellengröße Clamp size	Rohr-AD mm O.D. mm	Rohr-NW Tube NB	Rohr-AD Zoll Inch O.D.	Bestellzeichen Order Codes	Bestellzeichen Order Codes	Bestellzeichen Order Codes
1	6			RBPR 1-106	RBPR 3-106	RBPR 4-106
	6,4		1/4	RBPR 1-106,4	RBPR 3-106,4	RBPR 4-106,4
	8		5/16	RBPR 1-108	RBPR 3-108	RBPR 4-108
	9,5		3/8	RBPR 1-109,5	RBPR 3-109,5	RBPR 4-109,5
	10	G 1/8		RBPR 1-110	RBPR 3-110	RBPR 4-110
	12			RBPR 1-112	RBPR 3-112	RBPR 4-112
2	12,7		1/2	RBPR 1-212,7	RBPR 3-212,7	RBPR 4-212,7
	13,5	G 1/4		RBPR 1-213,5	RBPR 3-213,5	RBPR 4-213,5
	14			RBPR 1-214	RBPR 3-214	RBPR 4-214
	15			RBPR 1-215	RBPR 3-215	RBPR 4-215
	16		5/8	RBPR 1-216	RBPR 3-216	RBPR 4-216
	17,2	G 3/8		RBPR 1-217,2	RBPR 3-217,2	RBPR 4-217,2
3	18			RBPR 1-218	RBPR 3-218	RBPR 4-218
	19		3/4	RBPR 1-319	RBPR 3-319	RBPR 4-319
	20			RBPR 1-320	RBPR 3-320	RBPR 4-320
	21,3			RBPR 1-321,3	RBPR 3-321,3	RBPR 4-321,3
	22	G 1/2		RBPR 1-322	RBPR 3-322	RBPR 4-322
	25			RBPR 1-325	RBPR 3-325	RBPR 4-325
4	25,4		1	RBPR 1-325,4	RBPR 3-325,4	RBPR 4-325,4
	26,9	G 3/4		RBPR 1-426,9	RBPR 3-426,9	RBPR 4-426,9
	28			RBPR 1-428	RBPR 3-428	RBPR 4-428
5	30			RBPR 1-430	RBPR 3-430	RBPR 4-430
	32		1 1/4	RBPR 1-532	RBPR 3-532	RBPR 4-532
	33,7	G 1		RBPR 1-533,7	RBPR 3-533,7	RBPR 4-533,7
	35			RBPR 1-535	RBPR 3-535	RBPR 4-535
	38		1 1/2	RBPR 1-538	RBPR 3-538	RBPR 4-538
	40			RBPR 1-540	RBPR 3-540	RBPR 4-540
	42	G 1 1/4		RBPR 1-542	RBPR 3-542	RBPR 4-542

Werden andere Kombinationen benötigt, so bestellen Sie diese bitte in Einzelteilen (Bestellzeichen hierfür siehe Seiten 32 – 35).

Die Auslieferung erfolgt unmontiert in Einzelteilen.

³⁾Bei Montage von Vollgummi-Schellen sind Deckplatten, Sechskantschrauben und Sicherungsscheiben zu verwenden

If different combinations are required, we would be obliged if they could be ordered as separate components (Please refer to individual components, pages 32 – 35).

Delivery in unassembled individual components.

³⁾When assembling solid rubber tube clamps, cover plates, hexagon screws and locking washers must be used

Bestellzeichen

für Schellenhälften:

Polypropylen	RBPR
innen glatt	RBPG
Polyamid 6	RBNR
innen glatt	RBNG
Vollgummi	RBVG³⁾

Bei Bedarf Standardkurzzeichen RBPR in der Spalte „Bestellzeichen“ austauschen.

Order codes

for clamp-halves:

<i>Polypropylene</i>	RBPR
<i>inside smooth</i>	RBPG
<i>Polyamide 6</i>	RBNR
<i>inside smooth</i>	RBNG
<i>Rubber</i>	RBVG³⁾

Replace standard abbreviation RBPR in column "Order codes" as required.

2 Schellenhälften mit Tragschienen-Mutter, Deckplatte und Innensechskantschraube
2 clamp halves with rail nut, cover plate and hexagon socket head screw



2 Schellenhälften mit Aufbauschraube und Sicherungsblech
2 clamp halves with stacking bolt and locking plate



2 Schellenhälften mit Deckplatte und Sechskantschraube
2 clamp halves with cover plate and hexagon head screw



Schellengröße <i>Clamp size</i>	Rohr-AD mm <i>O.D. mm</i>	Rohr-NW <i>Tube NB</i>	Rohr-AD Zoll <i>Inch O.D.</i>	Bestellzeichen <i>Order Codes</i>	Bestellzeichen <i>Order Codes</i>	Bestellzeichen <i>Order Codes</i>
	d₁					
1	6			RBPR 5-106	RBPR 8-106	RBPR 16-106
	6,4		1/4	RBPR 5-106,4	RBPR 8-106,4	RBPR 16-106,4
	8		5/16	RBPR 5-108	RBPR 8-108	RBPR 16-108
	9,5		3/8	RBPR 5-109,5	RBPR 8-109,5	RBPR 16-109,5
	10	G 1/8		RBPR 5-110	RBPR 8-110	RBPR 16-110
	12			RBPR 5-112	RBPR 8-112	RBPR 16-112
2	12,7		1/2	RBPR 5-212,7	RBPR 8-212,7	RBPR 16-212,7
	13,5	G 1/4		RBPR 5-213,5	RBPR 8-213,5	RBPR 16-213,5
	14			RBPR 5-214	RBPR 8-214	RBPR 16-214
	15			RBPR 5-215	RBPR 8-215	RBPR 16-215
	16		5/8	RBPR 5-216	RBPR 8-216	RBPR 16-216
	17,2	G 3/8		RBPR 5-217,2	RBPR 8-217,2	RBPR 16-217,2
18			RBPR 5-218	RBPR 8-218	RBPR 16-218	
3	19		3/4	RBPR 5-319	RBPR 8-319	RBPR 16-319
	20			RBPR 5-320	RBPR 8-320	RBPR 16-320
	21,3	G 1/2		RBPR 5-321,3	RBPR 8-321,3	RBPR 16-321,3
	22			RBPR 5-322	RBPR 8-322	RBPR 16-322
	25			RBPR 5-325	RBPR 8-325	RBPR 16-325
	25,4		1	RBPR 5-325,4	RBPR 8-325,4	RBPR 16-325,4
4	26,9	G 3/4		RBPR 5-426,9	RBPR 8-426,9	RBPR 16-426,9
	28			RBPR 5-428	RBPR 8-428	RBPR 16-428
	30			RBPR 5-430	RBPR 8-430	RBPR 16-430
5	32		1 1/4	RBPR 5-532	RBPR 8-532	RBPR 16-532
	33,7	G 1		RBPR 5-533,7	RBPR 8-533,7	RBPR 16-533,7
	35			RBPR 5-535	RBPR 8-535	RBPR 16-535
	38		1 1/2	RBPR 5-538	RBPR 8-538	RBPR 16-538
	40			RBPR 5-540	RBPR 8-540	RBPR 16-540
	42	G 1 1/4		RBPR 5-542	RBPR 8-542	RBPR 16-542

Werden andere Kombinationen benötigt, so bestellen Sie diese bitte in Einzelteilen (Bestellzeichen hierfür siehe Seiten 32 – 35).
Die Auslieferung erfolgt unmontiert in Einzelteilen.

³⁾Bei Montage von Vollgummi-Schellen sind Deckplatten, Sechskantschrauben und Sicherungsscheiben zu verwenden

*If different combinations are required, we would be obliged if they could be ordered as separate components (Please refer to individual components, pages 32 – 35).
Delivery in unassembled individual components.*

³⁾When assembling solid rubber tube clamps, cover plates, hexagon screws and locking washers must be used

Das innovative Design

- von der Natur abgeschaut - die Wabenstruktur

Innovative design

- inspired by nature - Honeycomb-structure

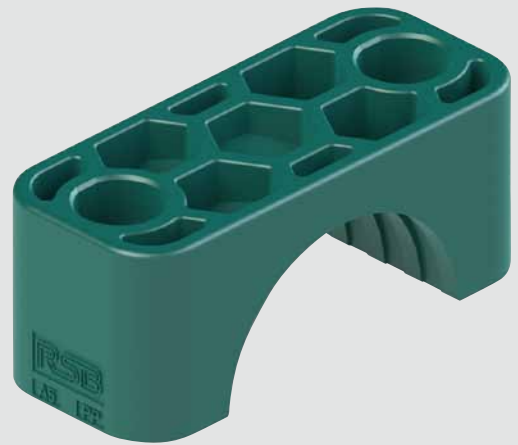

Die Vorteile

- Optimierte Produktgeometrie
- Beste Druckverteilung
- Höchstmögliche Rohrhaltekräfte

In allen Standardmaterialien verfügbar.

Advantages

- Optimised product-geometry
- Best possible distribution of pressure
- Highest tube holding force

All standard materials available.

Rohrschellen Serie C

Tube clamps Series C



Abmessungen und Gewichte von Komplettschellen

Dimensions and weights of tube clamps, complete

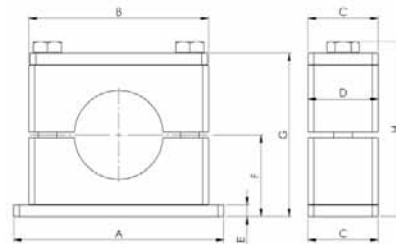

Größe Size	Abmessungen [mm] / Dimensions [mm]											Gewicht / 10 Stk. Weight / 10 Pcs. RCPR1-xxx [kg]
	A	B	C	D	E	F		G		H		
						Rippen Grooved	Glatt Smooth	Rippen Grooved	Glatt Smooth	Rippen Grooved	Glatt Smooth	
1	73	56	30	30	8	24	23	48	46	54,4	52,4	0,31
2	84	71	30	30	8	32	31	64	62	70,4	68,4	0,41
3	100	86	30	30	8	38	37	76	74	82,4	80,4	0,48
4	140	117	45	45	10	55	53,5	110	107	117,5	114,5	1,24
5	180	154	60	60	10	70	67,5	140	135	150	145	2,43
6	225	206	80	80	15	99	96	198	192	210,5	204,5	6,12
7	270	251	90	90	15	115	112	230	224	245	239	8,69
8	340	320	120	120	25	160	157	320	314	333,7	327,7	22,49
9	520	470	160	162	30	235	-	470	-	488,7	-	51,23
10	680	630	180	182	30	295	-	590	-	608,7	-	74,38

Das Gewicht wurde mit dem kleinsten Durchmesser (siehe Katalog) und der Standard-Ausführung der Stahlteile der jeweiligen Größe in losem Zustand ermittelt.

The weight was determined with the smallest diameter (see catalogue) and the standard model of the steel parts of the respective quantity in bulk.

Bestellzeichen

für Schellenhälften:

Polypropylen innen glatt	RCPR RCPG^{1) 2)}
Polyamid 6 innen glatt	RCNR RCNG^{1) 2)}
Vollgummi	RCVR^{1) 3)} RCVG^{1) 2) 3)}
Aluminium	RCAR

Order codes

for clamp-halves:

Polypropylene inside smooth	RCPR RCPG^{1) 2)}
Polyamide 6 inside smooth	RCNR RCNG^{1) 2)}
Rubber	RCVR^{1) 3)} RCVG^{1) 2) 3)}
Aluminium	RCAR

Bei Bedarf Standardkurzzeichen RCPR in der Spalte „Schellenhälften“ austauschen.

Replace standard abbreviation RCPR in column "clamp-halves" as required.

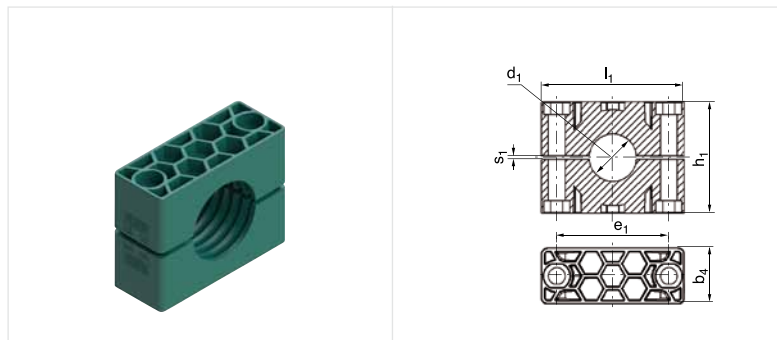

Schellengröße Clamp size	Rohr-AD mm O.D. mm	Rohr-NW Tube NB	Rohr-AD Zoll Inch O.D.	1 Stück / 2 Schellenhälften 1 part / 2 clamp-halves RCPR	2 Schellenhälften 2 clamp-halves RCPR-...						
					l ₁	h ₁	e ₁	s ₁	b ₁		
1	6	G 1/8	5/16 3/8	RCPR-106	56	32	33	2	30		
	8			RCPR-108							
	9,5			RCPR-109,5							
	10			RCPR-110							
	12			RCPR-112							
	12,7	G 1/4	1/2	RCPR-112,7							
	13,5			RCPR-113,5							
	14			RCPR-114							
	15			RCPR-115							
	16			RCPR-116							
17,2	G 3/8	5/8	RCPR-117,2								
18			RCPR-118								
19			G 1/2	3/4	RCPR-219						
20					RCPR-220						
21,3					RCPR-221,3						
22	RCPR-222										
23	RCPR-223										
25	G 3/4	1			RCPR-225						
25,4					RCPR-225,4						
26,9					RCPR-226,9						
28					RCPR-228						
30					RCPR-230						
3	30	G 1	1 1/4	RCPR-330	86	60	60	2	30		
	32			RCPR-332							
	33,7			RCPR-333,7							
	35			RCPR-335							
	38			G 1 1/4						1 1/2	RCPR-338
	40										RCPR-340
42	RCPR-342										
4	38	G 1 1/4	1 1/2	RCPR-438	117	90	90	3	45		
	40			RCPR-440							
	42			RCPR-442							
	45			RCPR-445							
	48,3			G 1 1/2						2	RCPR-448,3
	50										RCPR-450
	51	G 2	2 1/4	RCPR-451							
	52			RCPR-452							
	55			RCPR-455							
	57			RCPR-457							
	60,3			RCPR-460,3							
	63			G 3						2 1/2	RCPR-463
65	RCPR-465										
70	RCPR-470										
70	G 2 1/2	3	RCPR-565								
65			RCPR-570								
73			RCPR-573								
75			RCPR-575								
76,1			G 3 1/4	3 1/2	RCPR-576,1						
80					RCPR-580						
82,5			G 3	3 1/2	RCPR-582,5						
85					RCPR-585						
88,9					RCPR-588,9						
90			RCPR-590								

¹⁾Nur in Größen 1 – 8 ²⁾ohne Vorspannung

³⁾Bei Montage von Vollgummi-Schellen sind Deckplatten, Sechskantschrauben und Sicherungsscheiben zu verwenden

¹⁾Only sizes 1 – 8 ²⁾without prestress

³⁾When assembling solid rubber tube clamps, cover plates, hexagon screws and locking washers must be used

Bestellzeichen

für Schellenhälften:

Polypropylen innen glatt	RCPR RCPG^{1) 2)}
Polyamid 6 innen glatt	RCNR RCNG^{1) 2)}
Vollgummi	RCVR^{1) 3)} RCVG^{1) 2) 3)}
Aluminium	RCAR

Bei Bedarf Standard-
kurzzeichen RCPR in der Spalte
„Schellenhälften“ austauschen.

Order codes

for clamp-halves:

Polypropylene inside smooth	RCPR RCPG^{1) 2)}
Polyamide 6 inside smooth	RCNR RCNG^{1) 2)}
Rubber	RCVR^{1) 3)} RCVG^{1) 2) 3)}
Aluminium	RCAR

Replace standard abbreviation
RCPR in column "clamp-halves"
as required.

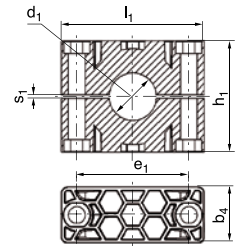

Schellengröße Clamp size	Rohr-AD mm O.D. mm	Rohr-NW Tube NB	Rohr-AD Zoll Inch O.D.	1 Stück / 2 Schellenhälften 1 part / 2 clamp-halves RCPR	2 Schellenhälften 2 clamp-halves RCPR-...				
					l ₁	h ₁	e ₁	s ₁	b ₄
6	90	G 3 1/2	4	RCPR-690 RCPR-697 RCPR-6100 RCPR-6101,6 RCPR-6108 RCPR-6114,3 RCPR-6127	206	168	168	6	80
	97								
	100								
	101,6								
	108	G 4	4 1/4						
	114,3								
127									
7	127	G 5	5	RCPR-7127 RCPR-7130 RCPR-7133 RCPR-7140 RCPR-7150 RCPR-7152,4 RCPR-7159 RCPR-7165,1 RCPR-7168,3	251	200	205	6	90
	130								
	133								
	140								
	150	G 5 1/2	6						
	152,4								
	159	G 6	6 1/4						
	165,1								
168,3									
8	168,3	G 6	6 5/8	RCPR-8168,3 RCPR-8177,8 RCPR-8193,7 RCPR-8203 RCPR-8219,1 RCPR-8220	320	270	265	6	120
	177,8								
	193,7								
	203								
	219,1	G 8	8						
	220								
9	219,1	G 8	8 5/8	RCPR-9219,1 RCPR-9244,5 RCPR-9273 RCPR-9323,9	470	410	395	20	162
	244,5								
	273	G 10	10 3/4						
	323,9								
10	355,6	G 14		RCPR-10355,6 RCPR-10406,4	630	530	534	20	182
	406,4								

¹⁾Nur in Größen 1 – 8 ²⁾ohne Vorspannung ³⁾Bei Montage von Vollgummi-Schellen sind Deckplatten, Sechskantschrauben und Sicherungsscheiben zu verwenden

¹⁾Only sizes 1 – 8 ²⁾without prestress ³⁾When assembling solid rubber tube clamps, cover plates, hexagon screws and locking washers must be used

Komplett-Programm siehe Seiten 45 bis 50

Complete range please refer to pages 45 to 50

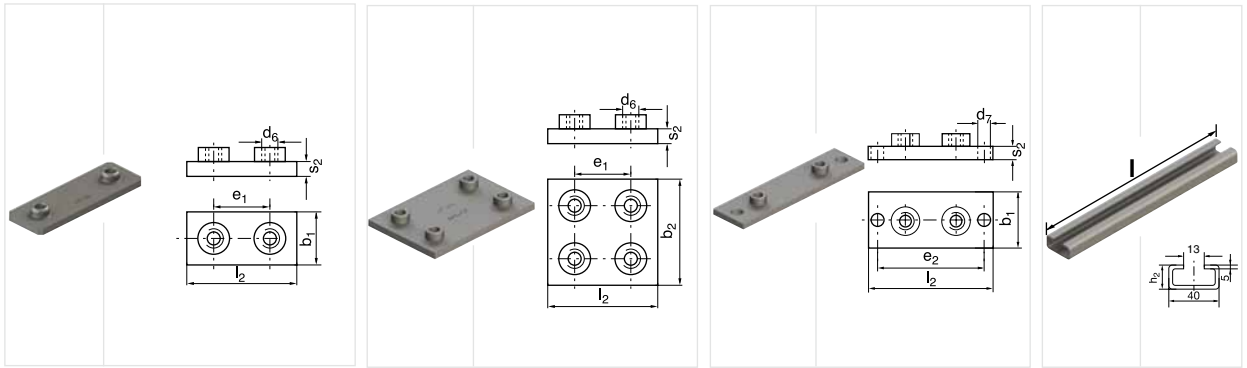

Schellengröße Clamp size	Anschweißplatte Weld plate AP-C						Anschweißplatte, doppelt Weld plate, double APD-C						Anschweiß- u. Schraubplatte Weld- and screw plate, elongated APL-C						Tragschiene Mounting rail TS-C		
	e ₁	b ₁	l ₂	s ₂	d ₆		e ₁	b ₂	l ₂	s ₂	d ₆		l ₂	b ₁	s ₂	e ₂	d ₇		l	h ₂	
1	AP-C 1	33	30	73	8	M 10	APD-C 1	33	60	73	8	M 10	APL-C 1	113	30	8	85	11	TS-C 1 TS-C 2	1m 2m	22
2	AP-C 2	45	30	84	8	M 10	APD-C 2	45	60	84	8	M 10	APL-C 2	125	30	8	97	11			
3	AP-C 3	60	30	100	8	M 10	APD-C 3	60	60	100	8	M 10	APL-C 3	140	30	8	112	11			
4	AP-C 4	90	45	140	10	M 12	APD-C 4	90	90	140	10	M 12	APL-C 4	190	45	10	160	14			
5	AP-C 5	122	60	180	10	M 16	APD-C 5	122	120	180	10	M 16	APL-C 5	240	60	10	205	18			
6	AP-C 6	168	80	225	15	M 20	APD-C 6	168	160	225	15	M 20	APL-C 6	310	80	15	270	22			
7	AP-C 7	205	90	270	15	M 24	APD-C 7	205	180	270	15	M 24	APL-C 7	370	90	15	320	26			
8	AP-C 8	265	120	340	25	M 30	APD-C 8	265	240	340	25	M 30	APL-C 8	450	120	25	390	33			
9	AP-C 9	395	160	520	30	M 30	APD-C 9	395	330	520	30	M 30									
10	AP-C 10	534	180	680	30	M 30	APD-C 10	534	364	680	30	M 30									

Metallteile in Edelstahl lieferbar.
All metal parts available in stainless steel.



Komplett-Programm siehe Seiten 45 bis 50

Complete range please refer to pages 45 to 50

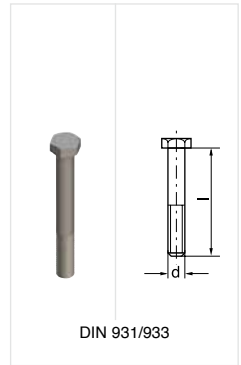
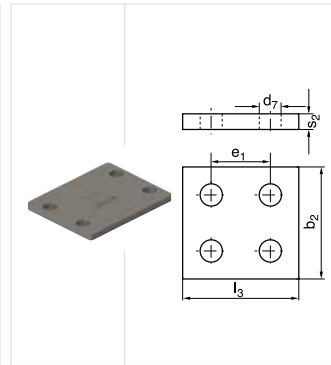
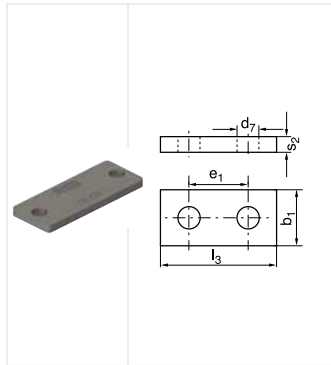
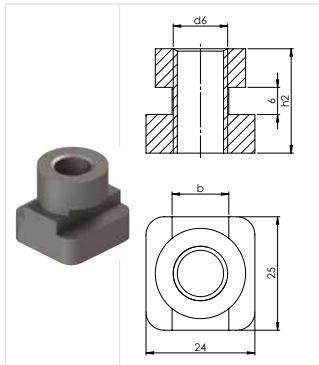

Schellengröße Clamp size	Tragschienen-Mutter Rail nut TM-C			Deckplatte Cover plate DP-C					Deckplatte, doppelt Cover plate, double DPD-C					Sechskantschraube Hexagon head screw SS-C				
	h ₂	b	d ₆	l ₃	e ₁	b ₁	s ₂	d ₇	l ₃	e ₁	b ₂	s ₂	d ₇	d	x	l		
1				DP-C 1	55	33	30	8	11	DPD-C 1	55	33	60	8	11	SS-C 1	M 10 x 40	
2	TM-C 1	20	12	M 10	DP-C 2	70	45	30	8	11	DPD-C 2	70	45	60	8	11	SS-C 2	M 10 x 60
3				DP-C 3	85	60	30	8	11	DPD-C 3	85	60	60	8	11	SS-C 3	M 10 x 70	
4	TM-C 4	23	12,5	M 12	DP-C 4	115	90	45	10	14	DPD-C 4	115	90	90	10	14	SS-C 4	M 12 x 100
5				DP-C 5	152	122	60	10	18	DPD-C 5	152	122	120	10	18	SS-C 5	M 16 x 130	
6				DP-C 6	205	168	80	15	22	DPD-C 6	205	168	160	15	24	SS-C 6	M 20 x 190	
7				DP-C 7	251	205	90	15	28	DPD-C 7	250	205	180	15	28	SS-C 7	M 24 x 220	
8				DP-C 8	320	265	120	25	35	DPD-C 8	322	265	240	25	35	SS-C 8	M 30 x 300	
9				DP-C 9	470	395	160	30	35	DPD-C 9	466	395	330	30	35	SS-C 9	M 30 x 450	
10				DP-C 10	630	534	180	30	35	DPD-C 10	630	534	360	30	35	SS-C 10	M 30 x 560	

Metalteile in Edelstahl lieferbar.
 All metal parts available in stainless steel.



Komplett-Programm siehe Seiten 45 bis 50

Complete range please refer to pages 45 to 50

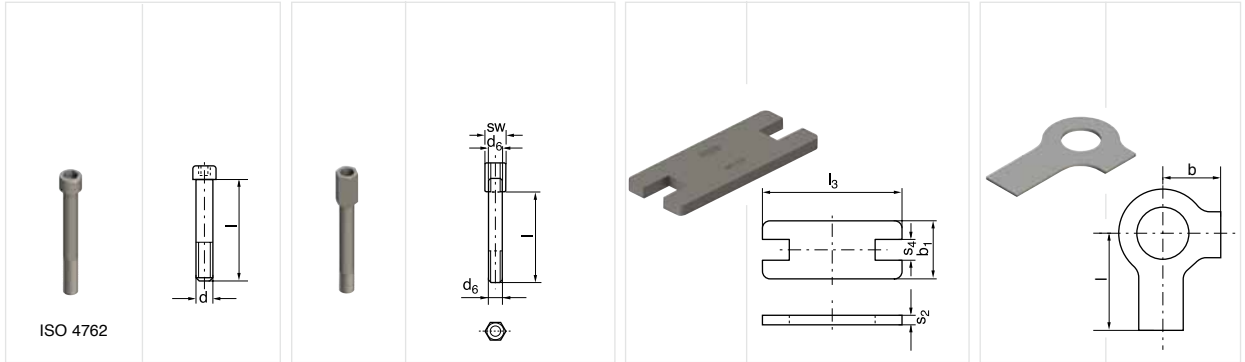

Schellengröße Clamp size	Innensechskantschraube Hexagon socket head screw IS-C	Aufbauschraube ¹⁾ Stacking bolt ¹⁾ AS-C				Sicherungsplatte ¹⁾ Locking plate ¹⁾ SP-C				Sicherungsscheibe ²⁾ Locking washer ²⁾ US-C						
		d	x	l	l	d ₆	sw	l ₃	b ₁	s ₂	s ₄	b	l			
1	IS-C 1	M 10	x	40	AS-C 1	25	M 10	15	SP-C 1	55	30	8	15,5			
2	IS-C 2	M 10	x	60	AS-C 2	40	M 10	15	SP-C 2	70	30	8	15,5	US-C 1	13	22
3	IS-C 3	M 10	x	70	AS-C 3	50	M 10	15	SP-C 3	85	30	8	15,5			
4	IS-C 4	M 12	x	100	AS-C 4	80	M 12	17	SP-C 4	115	45	10	17,5	US-C 4	15	28
5	IS-C 5	M 16	x	130	AS-C 5	110	M 16	21	SP-C 5	152	60	10	21,5	US-C 5	18	32
6	IS-C 6	M 20	x	190	AS-C 6	155	M 20	27	SP-C 6	205	80	15	27,5	US-C 6	21	36
7	IS-C 7	M 24	x	220	AS-C 7	180	M 24	30	SP-C 7	250	90	15	30,5	US-C 7	25	42
8	IS-C 8	M 30	x	300	AS-C 8	250	M 30	36	SP-C 8	320	120	25	36,5	US-C 8	32	52
9	IS-C 9	M 30	x	450												
10	IS-C 10	M 30	x	560												

Metallteile in Edelstahl lieferbar.

¹⁾Für den Einsatz von Aufbauschrauben bei Aufbaumontage sind Sicherungsplatten notwendig

²⁾Bei Montage von Vollgummi-Schellen sind Deckplatten, Sechskantschrauben und Sicherungsscheiben zu verwenden

All metal parts available in stainless steel.

¹⁾The usage of stacking bolts necessitates the deployment of locking plates during the construction assembly

²⁾When assembling solid rubber clamps, cover plates, hexagon screws and locking washers must be used



Bestellzeichen

für Schellenhälften:

Polypropylen	RCPR
innen glatt	RCPG¹⁾
Polyamid 6	RCNR
innen glatt	RCNG¹⁾
Vollgummi	RCVR^{1) 3)}
	RCVG^{1) 3)}
Aluminium	RCAR

Bei Bedarf Standardkurzzeichen RCPR in der Spalte „Bestellzeichen“ austauschen.

Order codes

for clamp-halves:

Polypropylene	RCPR
inside smooth	RCPG¹⁾
Polyamide 6	RCNR
inside smooth	RCNG¹⁾
Rubber	RCVR^{1) 3)}
	RCVG^{1) 3)}
Aluminium	RCAR

Replace standard abbreviation RCPR in column "Order codes" as required.

2 Schellenhälften mit
Anschweißplatte, Deckplatte
und Sechskantschrauben

2 clamp halves with weld plate,
cover plate and hexagon head screws



2 Schellenhälften mit
Anschweißplatte, Deckplatte
und Innensechskantschrauben

2 clamp halves with weld plate,
cover plate and hexagon socket head screws



Schellengröße Clamp size	Rohr-AD mm O.D. mm	Rohr-NW Tube NB	Rohr-AD Zoll Inch O.D.	Bestellzeichen Order Codes	Bestellzeichen Order Codes
1	6	G 1/8	5/16	RCPR 1-106	RCPR 2-106
	8			RCPR 1-108	RCPR 2-108
	9,5		RCPR 1-109,5	RCPR 2-109,5	
	10		RCPR 1-110	RCPR 2-110	
	12		RCPR 1-112	RCPR 2-112	
	12,7	G 1/4	1/2	RCPR 1-112,7	RCPR 2-112,7
	13,5			RCPR 1-113,5	RCPR 2-113,5
	14		G 3/8	5/8	RCPR 1-114
	15	RCPR 1-115			RCPR 2-115
	16	RCPR 1-116		RCPR 2-116	
	17,2	RCPR 1-117,2		RCPR 2-117,2	
18	RCPR 1-118	RCPR 2-118			
2	19	G 1/2	3/4	RCPR 1-219	RCPR 2-219
	20			RCPR 1-220	RCPR 2-220
	21,3		RCPR 1-221,3	RCPR 2-221,3	
	22		RCPR 1-222	RCPR 2-222	
	23		RCPR 1-223	RCPR 2-223	
	25	G 3/4	1	RCPR 1-225	RCPR 2-225
	25,4			RCPR 1-225,4	RCPR 2-225,4
	26,9			RCPR 1-226,9	RCPR 2-226,9
	28			RCPR 1-228	RCPR 2-228
	30			RCPR 1-230	RCPR 2-230
3	30	G 1	1 1/4	RCPR 1-330	RCPR 2-330
	32			RCPR 1-332	RCPR 2-332
	33,7		RCPR 1-333,7	RCPR 2-333,7	
	35		RCPR 1-335	RCPR 2-335	
	38	G 1 1/4	1 1/2	RCPR 1-338	RCPR 2-338
	40			RCPR 1-340	RCPR 2-340
	42			RCPR 1-342	RCPR 2-342
4	38	G 1 1/4	1 1/2	RCPR 1-438	RCPR 2-438
	40			RCPR 1-440	RCPR 2-440
	42			RCPR 1-442	RCPR 2-442
	45			RCPR 1-445	RCPR 2-445
	48,3			G 1 1/2	2
	50	RCPR 1-450	RCPR 2-450		
	51	RCPR 1-451	RCPR 2-451		
	52	G 2	2 1/4	RCPR 1-452	RCPR 2-452
	55			RCPR 1-455	RCPR 2-455
	57			RCPR 1-457	RCPR 2-457
	60,3			RCPR 1-460,3	RCPR 2-460,3
	63			RCPR 1-463	RCPR 2-463
	65			RCPR 1-465	RCPR 2-465
70	RCPR 1-470			RCPR 2-470	
5	65	G 2 1/2	3	RCPR 1-565	RCPR 2-565
	70			RCPR 1-570	RCPR 2-570
	73			RCPR 1-573	RCPR 2-573
	75			RCPR 1-575	RCPR 2-575
	76,1			G 3	3 1/4
	80	RCPR 1-580	RCPR 2-580		
	82,5	RCPR 1-582,5	RCPR 2-582,5		
	85	G 3	3 1/2	RCPR 1-585	RCPR 2-585
	88,9			RCPR 1-588,9	RCPR 2-588,9
	90			RCPR 1-590	RCPR 2-590

Werden andere Kombinationen benötigt, so bestellen Sie diese bitte in Einzelteilen (Bestellzeichen hierfür siehe Seiten 40 – 44).
Die Auslieferung erfolgt unmontiert in Einzelteilen. ¹⁾Nur in Größen 1 – 8 ³⁾Bei Montage von Vollgummi-Schellen sind Deckplatten, Sechskantschrauben und Sicherungsscheiben zu verwenden
If different combinations are required, we would be obliged if they could be ordered as separate components (Please refer to individual components, pages 40 – 44).
Delivery in unassembled individual components. ¹⁾Only sizes 1 – 8 ³⁾When assembling solid rubber tube clamps, cover plates, hexagon screws and locking washers must be used

Bestellzeichen

für Schellenhälften:

Polypropylen innen glatt	RCPR RCPG¹⁾
Polyamid 6 innen glatt	RCNR RCNG¹⁾
Vollgummi	RCVR^{1) 3)} RCVG^{1) 3)}
Aluminium	RCAR

Bei Bedarf Standardkurzzeichen RCPR in der Spalte „Bestellzeichen“ austauschen.

Order codes

for clamp-halves:

<i>Polypropylene</i> <i>inside smooth</i>	RCPR RCPG¹⁾
<i>Polyamide 6</i> <i>inside smooth</i>	RCNR RCNG¹⁾
<i>Rubber</i>	RCVR^{1) 3)} RCVG^{1) 3)}
<i>Aluminium</i>	RCAR

Replace standard abbreviation RCPR in column "Order codes" as required.

2 Schellenhälften mit
Anschweißplatte, Deckplatte
und Sechskantschrauben
*2 clamp halves with weld plate,
cover plate and hexagon head screws*



2 Schellenhälften mit
Anschweißplatte, Deckplatte
und Innensechskantschrauben
*2 clamp halves with weld plate,
cover plate and hexagon socket head screws*



Schellengröße Clamp size	Rohr-AD mm O.D. mm	Rohr-NW Tube NB	Rohr-AD Zoll Inch O.D.	Bestellzeichen Order Codes	Bestellzeichen Order Codes
6	90	G 3 1/2	4	RCPR 1-690 RCPR 1-697 RCPR 1-6100 RCPR 1-6101,6 RCPR 1-6108 RCPR 1-6114,3 RCPR 1-6127	RCPR 2-690 RCPR 2-697 RCPR 2-6100 RCPR 2-6101,6 RCPR 2-6108 RCPR 2-6114,3 RCPR 2-6127
	97		4 1/4		
	100		4 1/2		
	101,6		5		
	108	G 4	5 1/4		
	114,3		5 1/2		
7	127	G 5	5	RCPR 1-7127 RCPR 1-7130 RCPR 1-7133 RCPR 1-7140 RCPR 1-7150 RCPR 1-7152,4 RCPR 1-7159 RCPR 1-7165,1 RCPR 1-7168,3	RCPR 2-7127 RCPR 2-7130 RCPR 2-7133 RCPR 2-7140 RCPR 2-7150 RCPR 2-7152,4 RCPR 2-7159 RCPR 2-7165,1 RCPR 2-7168,3
	130		5 1/4		
	133		5 1/2		
	140		6		
	150	G 5 1/2	6 1/4		
	152,4		6 1/2		
	159	G 6	6 5/8		
	165,1		7		
8	168,3	G 8	7 5/8	RCPR 1-8168,3 RCPR 1-8177,8 RCPR 1-8193,7 RCPR 1-8203 RCPR 1-8219,1 RCPR 1-8220	RCPR 2-8168,3 RCPR 2-8177,8 RCPR 2-8193,7 RCPR 2-8203 RCPR 2-8219,1 RCPR 2-8220
	177,8		8 5/8		
	193,7				
	203				
	219,1				
9	219,1	G 8		RCPR 1-9219,1 RCPR 1-9244,5 RCPR 1-9273 RCPR 1-9323,9	RCPR 2-9219,1 RCPR 2-9244,5 RCPR 2-9273 RCPR 2-9323,9
	244,5				
	273	G 10	10 3/4		
	323,9	G 12	12 3/4		
10	355,6	G 14 G 16		RCPR 1-10355,6 RCPR 1-10406,4	RCPR 2-10355,6 RCPR 2-10406,4
	406,4				

Werden andere Kombinationen benötigt, so bestellen Sie diese bitte in Einzelteilen (Bestellzeichen hierfür siehe Seiten 40 – 44).
Die Auslieferung erfolgt unmontiert in Einzelteilen. ¹⁾Nur in Größen 1 – 8 ³⁾Bei Montage von Vollgummi-Schellen sind Deckplatten, Sechskantschrauben und Sicherungsscheiben zu verwenden
*If different combinations are required, we would be obliged if they could be ordered as separate components (Please refer to individual components, pages 40 – 44).
Delivery in unassembled individual components. ¹⁾Only sizes 1 – 8 ³⁾When assembling solid rubber tube clamps, cover plates, hexagon screws and locking washers must be used*

Bestellzeichen

für Schellenhälften:

Polypropylen innen glatt	RCPR RCPG¹⁾
Polyamid 6 innen glatt	RCNR RCNG¹⁾
Vollgummi	RCVR^{1) 3)} RCVG^{1) 3)}
Aluminium	RCAR

Bei Bedarf Standardkurzzeichen RCPR in der Spalte „Bestellzeichen“ austauschen.

Order codes

for clamp-halves:

<i>Polypropylene</i> <i>inside smooth</i>	RCPR RCPG¹⁾
<i>Polyamide 6</i> <i>inside smooth</i>	RCNR RCNG¹⁾
<i>Rubber</i>	RCVR^{1) 3)} RCVG^{1) 3)}
<i>Aluminium</i>	RCAR

Replace standard abbreviation RCPR in column "Order codes" as required.

2 Schellenhälften mit Tragschienen-Muttern, Deckplatte und Sechskantschrauben
2 clamp halves with rail nut, cover plate and hexagon head screws



2 Schellenhälften mit Tragschienen-Muttern, Deckplatte und Innensechskantschrauben
2 clamp halves with rail nut, cover plate and hexagon socket head screws



2 Schellenhälften mit Aufbauschrauben und Sicherungsplatte
2 clamp halves with stacking bolts and locking plate



Schellengröße Clamp size	Rohr-AD mm O.D. mm	Rohr-NW Tube NB	Rohr-AD Zoll Inch O.D.	Bestellzeichen Order Codes	Bestellzeichen Order Codes	Bestellzeichen Order Codes
1	6	G 1/8	5/16 3/8	RCPR 3-106	RCPR 4-106	RCPR 5-106
	8			RCPR 3-108	RCPR 4-108	RCPR 5-108
	9,5			RCPR 3-109,5	RCPR 4-109,5	RCPR 5-109,5
	10	G 1/4	1/2	RCPR 3-110	RCPR 4-110	RCPR 5-110
	12			RCPR 3-112	RCPR 4-112	RCPR 5-112
	12,7			RCPR 3-112,7	RCPR 4-112,7	RCPR 5-112,7
	13,5			RCPR 3-113,5	RCPR 4-113,5	RCPR 5-113,5
	14	G 3/8	5/8	RCPR 3-114	RCPR 4-114	RCPR 5-114
	15			RCPR 3-115	RCPR 4-115	RCPR 5-115
	16			RCPR 3-116	RCPR 4-116	RCPR 5-116
	17,2			RCPR 3-117,2	RCPR 4-117,2	RCPR 5-117,2
18	RCPR 3-118			RCPR 4-118	RCPR 5-118	
2	19	G 1/2	3/4	RCPR 3-219	RCPR 4-219	RCPR 5-219
	20			RCPR 3-220	RCPR 4-220	RCPR 5-220
	21,3			RCPR 3-221,3	RCPR 4-221,3	RCPR 5-221,3
	22			RCPR 3-222	RCPR 4-222	RCPR 5-222
	23			RCPR 3-223	RCPR 4-223	RCPR 5-223
	25			RCPR 3-225	RCPR 4-225	RCPR 5-225
	25,4			RCPR 3-225,4	RCPR 4-225,4	RCPR 5-225,4
	26,9			RCPR 3-226,9	RCPR 4-226,9	RCPR 5-226,9
	28			RCPR 3-228	RCPR 4-228	RCPR 5-228
	30			RCPR 3-230	RCPR 4-230	RCPR 5-230
3	30	G 1	1 1/4	RCPR 3-330	RCPR 4-330	RCPR 5-330
	32			RCPR 3-332	RCPR 4-332	RCPR 5-332
	33,7			RCPR 3-333,7	RCPR 4-333,7	RCPR 5-333,7
	35			RCPR 3-335	RCPR 4-335	RCPR 5-335
	38			RCPR 3-338	RCPR 4-338	RCPR 5-338
	40			RCPR 3-340	RCPR 4-340	RCPR 5-340
	42			RCPR 3-342	RCPR 4-342	RCPR 5-342
4	38	G 1 1/4	1 1/2	RCPR 3-438	RCPR 4-438	RCPR 5-438
	40			RCPR 3-440	RCPR 4-440	RCPR 5-440
	42			RCPR 3-442	RCPR 4-442	RCPR 5-442
	45	G 1 1/2	2	RCPR 3-445	RCPR 4-445	RCPR 5-445
	48,3			RCPR 3-448,3	RCPR 4-448,3	RCPR 5-448,3
	50			RCPR 3-450	RCPR 4-450	RCPR 5-450
	51			RCPR 3-451	RCPR 4-451	RCPR 5-451
	52	G 2	2 1/4	RCPR 3-452	RCPR 4-452	RCPR 5-452
	55			RCPR 3-455	RCPR 4-455	RCPR 5-455
	57			RCPR 3-457	RCPR 4-457	RCPR 5-457
	60,3			RCPR 3-460,3	RCPR 4-460,3	RCPR 5-460,3
	63			RCPR 3-463	RCPR 4-463	RCPR 5-463
	65	G 3	3 1/2	RCPR 3-465	RCPR 4-465	RCPR 5-465
70	RCPR 3-470			RCPR 4-470	RCPR 5-470	
65	G 2 1/2			3	RCPR 5-565	RCPR 5-570
70		RCPR 5-575	RCPR 5-576,1		RCPR 5-580	
73		RCPR 5-582,5	RCPR 5-585		RCPR 5-588,9	
75		RCPR 5-585	RCPR 5-590			
76,1						
80						
82,5						
85						
88,9						
90						

Werden andere Kombinationen benötigt, so bestellen Sie diese bitte in Einzelteilen (Bestellzeichen hierfür siehe Seiten 40 – 44). Die Auslieferung erfolgt unmontiert in Einzelteilen. ¹⁾Nur in Größen 1 – 8 ³⁾Bei Montage von Vollgummi-Schellen sind Deckplatten, Sechskantschrauben und Sicherungsscheiben zu verwenden
If different combinations are required, we would be obliged if they could be ordered as separate components (Please refer to individual components, pages 40 – 44). Delivery in unassembled individual components. ¹⁾Only sizes 1 – 8 ³⁾When assembling solid rubber tube clamps, cover plates, hexagon screws and locking washers must be used

Bestellzeichen

für Schellenhälften:

Polypropylen innen glatt	RCPR RCPG¹⁾
Polyamid 6 innen glatt	RCNR RCNG¹⁾
Vollgummi	RCVR^{1) 3)} RCVG^{1) 3)}
Aluminium	RCAR

Bei Bedarf Standardkurzzeichen RCPR in der Spalte „Bestellzeichen“ austauschen.

Order codes

for clamp-halves:

Polypropylene inside smooth	RCPR RCPG¹⁾
Polyamide 6 inside smooth	RCNR RCNG¹⁾
Rubber	RCVR^{1) 3)} RCVG^{1) 3)}
Aluminium	RCAR

Replace standard abbreviation RCPR in column "Order codes" as required.

2 Schellenhälften mit Tragschienen-Muttern, Deckplatte und Sechskantschrauben
2 clamp halves with rail nut, cover plate and hexagon head screws



2 Schellenhälften mit Tragschienen-Muttern, Deckplatte und Innensechskantschrauben
2 clamp halves with rail nut, cover plate and hexagon socket head screws



2 Schellenhälften mit Aufbauschrauben und Sicherungsplatte
2 clamp halves with stacking bolts and locking plate



Schellengröße Clamp size	Rohr-AD mm O.D. mm	Rohr-NW Tube NB	Rohr-AD Zoll Inch O.D.	Bestellzeichen Order Codes	Bestellzeichen Order Codes	Bestellzeichen Order Codes		
6	90	G 3 ¹ / ₂	4			RCPR 5-690 RCPR 5-697 RCPR 5-6100 RCPR 5-6101,6 RCPR 5-6108 RCPR 5-6114,3 RCPR 5-6127		
	97		4 ¹ / ₄					
	100		4 ¹ / ₂					
	101,6		5					
	108	G 4	5 ¹ / ₄					
	114,3						5 ¹ / ₂	
127	G 5	5			RCPR 5-7127 RCPR 5-7130 RCPR 5-7133 RCPR 5-7140 RCPR 5-7150 RCPR 5-7152,4 RCPR 5-7159 RCPR 5-7165,1 RCPR 5-7168,3			
7						127	5 ¹ / ₂	6
						130		
						133	6 ¹ / ₂	
						140		6 ⁵ / ₈
						150	G 6	
	152,4	8 ⁵ / ₈						
159	G 8							
165,1			203					
168,3				219,1				
8		168,3			220			
	177,8	RCPR 5-8168,3 RCPR 5-8177,8 RCPR 5-8193,7 RCPR 5-8203 RCPR 5-8219,1 RCPR 5-8220						
	193,7							
	203							
219,1								
220								

Werden andere Kombinationen benötigt, so bestellen Sie diese bitte in Einzelteilen (Bestellzeichen hierfür siehe Seiten 40 – 44). Die Auslieferung erfolgt unmontiert in Einzelteilen. ¹⁾Nur in Größen 1 – 8 ³⁾Bei Montage von Vollgummi-Schellen sind Deckplatten, Sechskantschrauben und Sicherungsscheiben zu verwenden
If different combinations are required, we would be obliged if they could be ordered as separate components (Please refer to individual components, pages 40 – 44).
Delivery in unassembled individual components. ¹⁾Only sizes 1 – 8 ³⁾When assembling solid rubber tube clamps, cover plates, hexagon screws and locking washers must be used

Bestellzeichen

für Schellenhälften:

Polypropylen innen glatt	RCPR RCPG¹⁾
Polyamid 6 innen glatt	RCNR RCNG¹⁾
Vollgummi	RCVR^{1) 3)} RCVG^{1) 3)}
Aluminium	RCAR

Bei Bedarf Standardkurzzeichen RCPR in der Spalte „Bestellzeichen“ austauschen.

Order codes

for clamp-halves:

Polypropylene inside smooth	RCPR RCPG¹⁾
Polyamide 6 inside smooth	RCNR RCNG¹⁾
Rubber	RCVR^{1) 3)} RCVG^{1) 3)}
Aluminium	RCAR

Replace standard abbreviation RCPR in column "Order codes" as required.

4 Schellenhälften mit Doppelansweißplatte, Doppel-Deckplatte und Sechskantschrauben
4 clamp halves with double weld plate, double cover plate and hexagon head screws



4 Schellenhälften mit Doppelansweißplatte, Doppel-Deckplatte und Innensechskantschrauben
4 clamp halves with double weld plate, double cover plate and hexagon socket head screws



Schellengröße Clamp size	Rohr-AD mm O.D. mm	Rohr-NW Tube NB	Rohr-AD Zoll Inch O.D.	Bestellzeichen Order Codes	Bestellzeichen Order Codes
1	6	G 1/8	5/16 3/8	RCPDR 1-106	RCPDR 2-106
	8			RCPDR 1-108	RCPDR 2-108
	9,5			RCPDR 1-109,5	RCPDR 2-109,5
	10			RCPDR 1-110	RCPDR 2-110
	12	G 1/4	1/2	RCPDR 1-112	RCPDR 2-112
	12,7			RCPDR 1-112,7	RCPDR 2-112,7
	13,5			RCPDR 1-113,5	RCPDR 2-113,5
	14			RCPDR 1-114	RCPDR 2-114
	15	G 3/8	5/8	RCPDR 1-115	RCPDR 2-115
	16			RCPDR 1-116	RCPDR 2-116
17,2	RCPDR 1-117,2			RCPDR 2-117,2	
18	RCPDR 1-118			RCPDR 2-118	
2	19	G 1/2	3/4	RCPDR 1-219	RCPDR 2-219
	20			RCPDR 1-220	RCPDR 2-220
	21,3			RCPDR 1-221,3	RCPDR 2-221,3
	22			RCPDR 1-222	RCPDR 2-222
	23	G 3/4	1	RCPDR 1-223	RCPDR 2-223
	25			RCPDR 1-225	RCPDR 2-225
	25,4			RCPDR 1-225,4	RCPDR 2-225,4
	26,9			RCPDR 1-226,9	RCPDR 2-226,9
	28			RCPDR 1-228	RCPDR 2-228
	30			RCPDR 1-230	RCPDR 2-230
3	30	G 1	1 1/4	RCPDR 1-330	RCPDR 2-330
	32			RCPDR 1-332	RCPDR 2-332
	33,7			RCPDR 1-333,7	RCPDR 2-333,7
	35			RCPDR 1-335	RCPDR 2-335
	38	G 1 1/4	1 1/2	RCPDR 1-338	RCPDR 2-338
	40			RCPDR 1-340	RCPDR 2-340
	42			RCPDR 1-342	RCPDR 2-342
4	38	G 1 1/4	1 1/2	RCPDR 1-438	RCPDR 2-438
	40			RCPDR 1-440	RCPDR 2-440
	42			RCPDR 1-442	RCPDR 2-442
	45			RCPDR 1-445	RCPDR 2-445
	48,3	G 1 1/2	2	RCPDR 1-448,3	RCPDR 2-448,3
	50			RCPDR 1-450	RCPDR 2-450
	51			RCPDR 1-451	RCPDR 2-451
	52	G 2	2 1/4	RCPDR 1-452	RCPDR 2-452
	55			RCPDR 1-455	RCPDR 2-455
	57			RCPDR 1-457	RCPDR 2-457
	60,3			RCPDR 1-460,3	RCPDR 2-460,3
63	RCPDR 1-463			RCPDR 2-463	
65	G 3	3 1/2	RCPDR 1-465	RCPDR 2-465	
70			RCPDR 1-470	RCPDR 2-470	
5	65	G 2 1/2	3	RCPDR 1-565	RCPDR 2-565
	70			RCPDR 1-570	RCPDR 2-570
	73			RCPDR 1-573	RCPDR 2-573
	75			RCPDR 1-575	RCPDR 2-575
	76,1			RCPDR 1-576,1	RCPDR 2-576,1
	80	G 3	3 1/4	RCPDR 1-580	RCPDR 2-580
	82,5			RCPDR 1-582,5	RCPDR 2-582,5
	85			RCPDR 1-585	RCPDR 2-585
	88,9	G 3	3 1/2	RCPDR 1-588,9	RCPDR 2-588,9
	90			RCPDR 1-590	RCPDR 2-590

Werden andere Kombinationen benötigt, so bestellen Sie diese bitte in Einzelteilen (Bestellzeichen hierfür siehe Seiten 40 – 44). Die Auslieferung erfolgt unmontiert in Einzelteilen. ¹⁾Nur in Größen 1 – 8 ³⁾Bei Montage von Vollgummi-Schellen sind Deckplatten, Sechskantschrauben und Sicherungsscheiben zu verwenden
If different combinations are required, we would be obliged if they could be ordered as separate components (Please refer to individual components, pages 40 – 44). Delivery in unassembled individual components. ¹⁾Only sizes 1 – 8 ³⁾When assembling solid rubber tube clamps, cover plates, hexagon screws and locking washers must be used

Bestellzeichen

für Schellenhälften:

Polypropylen innen glatt	RCPR RCPG¹⁾
Polyamid 6 innen glatt	RCNR RCNG¹⁾
Vollgummi	RCVR^{1) 3)} RCVG^{1) 3)}
Aluminium	RCAR

Bei Bedarf Standardkurzzeichen RCPR in der Spalte „Bestellzeichen“ austauschen.

Order codes

for clamp-halves:

Polypropylene inside smooth	RCPR RCPG¹⁾
Polyamide 6 inside smooth	RCNR RCNG¹⁾
Rubber	RCVR^{1) 3)} RCVG^{1) 3)}
Aluminium	RCAR

Replace standard abbreviation RCPR in column "Order codes" as required.

4 Schellenhälften mit Doppelanschweißplatte, Doppel-Deckplatte und Sechskantschrauben
4 clamp halves with double weld plate, double cover plate and hexagon head screws



4 Schellenhälften mit Doppelanschweißplatte, Doppel-Deckplatte und Innensechskantschrauben
4 clamp halves with double weld plate, double cover plate and hexagon socket head screws



Schellengröße Clamp size	Rohr-AD mm O.D. mm	Rohr-NW Tube NB	Rohr-AD Zoll Inch O.D.	Bestellzeichen Order Codes	Bestellzeichen Order Codes
6	90	G 3 ¹ / ₂	4	RCPDR 1-690	RCPDR 2-690
	97			RCPDR 1-697	RCPDR 2-697
	100			RCPDR 1-6100	RCPDR 2-6100
	101,6			RCPDR 1-6101,6	RCPDR 2-6101,6
	108	G 4	4 ¹ / ₄	RCPDR 1-6108	RCPDR 2-6108
	114,3			RCPDR 1-6114,3	RCPDR 2-6114,3
	127		5	RCPDR 1-6127	RCPDR 2-6127
7	127	G 5	5	RCPDR 1-7127	RCPDR 2-7127
	130			RCPDR 1-7130	RCPDR 2-7130
	133			RCPDR 1-7133	RCPDR 2-7133
	140			RCPDR 1-7140	RCPDR 2-7140
	150	G 5 ¹ / ₂	6	RCPDR 1-7150	RCPDR 2-7150
	152,4			RCPDR 1-7152,4	RCPDR 2-7152,4
	159	G 6	6 ¹ / ₄	RCPDR 1-7159	RCPDR 2-7159
	165,1			RCPDR 1-7165,1	RCPDR 2-7165,1
168,3	RCPDR 1-7168,3			RCPDR 2-7168,3	
8	168,3	G 8	6 ⁵ / ₈	RCPDR 1-8168,3	RCPDR 2-8168,3
	177,8		7	RCPDR 1-8177,8	RCPDR 2-8177,8
	193,7		7 ⁵ / ₈	RCPDR 1-8193,7	RCPDR 2-8193,7
	203		8 ⁵ / ₈	RCPDR 1-8203	RCPDR 2-8203
	219,1			RCPDR 1-8219,1	RCPDR 2-8219,1
	220			RCPDR 1-8220	RCPDR 2-8220
9	219,1	G 8		RCPDR 1-9219,1	RCPDR 2-9219,1
	244,5			RCPDR 1-9244,5	RCPDR 2-9244,5
	273	G 10		RCPDR 1-9273	RCPDR 2-9273
	323,9	G 12		RCPDR 1-9323,9	RCPDR 2-9323,9
10	355,6	G 14 G 16		RCPDR 1-10355,6	RCPDR 2-10355,6
	406,4			RCPDR 1-10406,4	RCPDR 2-10406,4

Werden andere Kombinationen benötigt, so bestellen Sie diese bitte in Einzelteilen (Bestellzeichen hierfür siehe Seiten 40 – 44).
Die Auslieferung erfolgt unmontiert in Einzelteilen. ¹⁾Nur in Größen 1 – 8 ³⁾Bei Montage von Vollgummi-Schellen sind Deckplatten, Sechskantschrauben und Sicherungsscheiben zu verwenden
If different combinations are required, we would be obliged if they could be ordered as separate components (Please refer to individual components, pages 40 – 44).
Delivery in unassembled individual components. ¹⁾Only sizes 1 – 8 ³⁾When assembling solid rubber tube clamps, cover plates, hexagon screws and locking washers must be used

Befestigungsadapter

Fixed adaptor

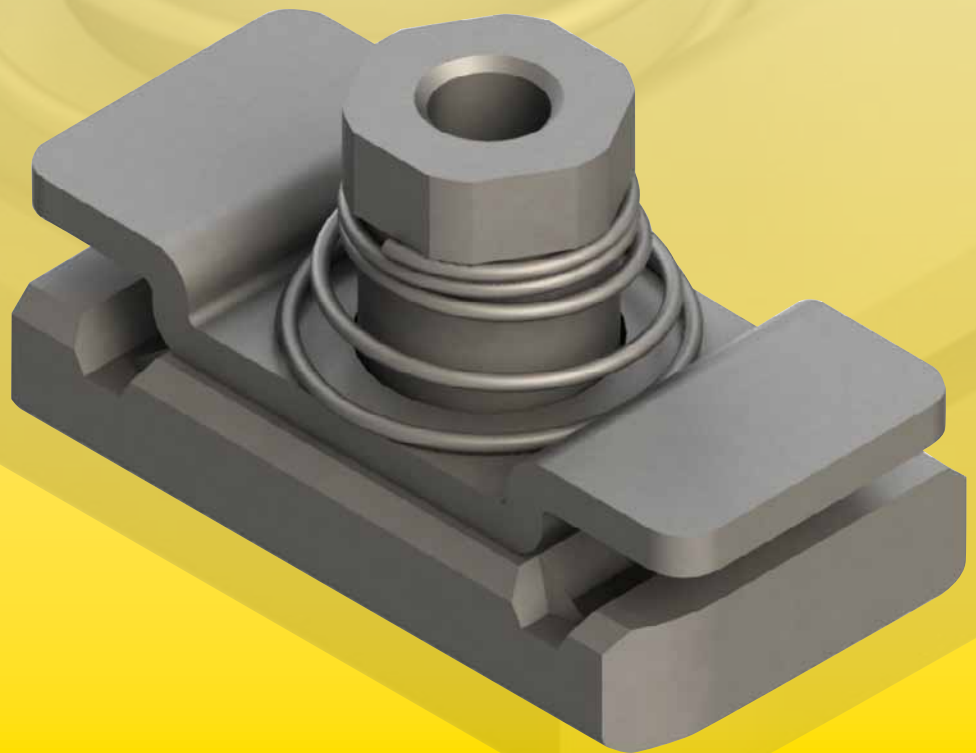

**BEFESTIGUNGSADAPTER FÜR SERIE A
FIXED ADAPTOR FOR SERIES A**

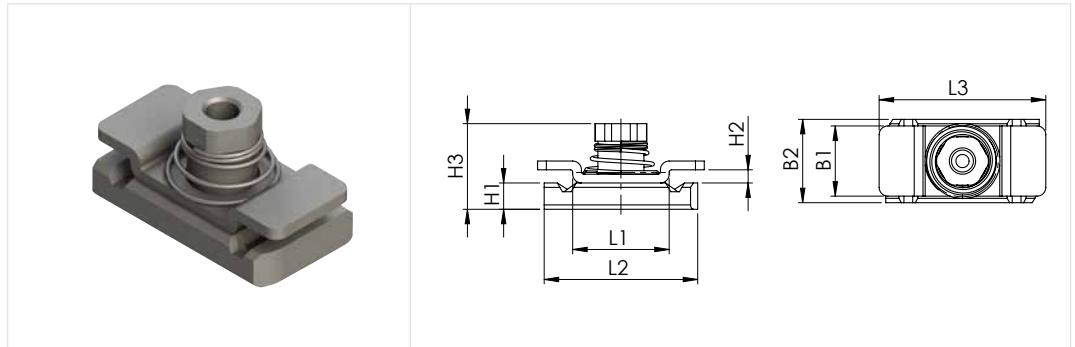

Schellengröße Clamp size	Befestigungsadapter Fixed adaptor									
	BA	L1	L2	L3	B1	B2	H1	H2	H3	d6
1	BA-A/B1	22	35	38	16	19	6	3	19,5	M6
2										
3										
4										
5										
6										
7										
8										

**BEFESTIGUNGSADAPTER FÜR SERIE B
FIXED ADAPTOR FOR SERIES B**

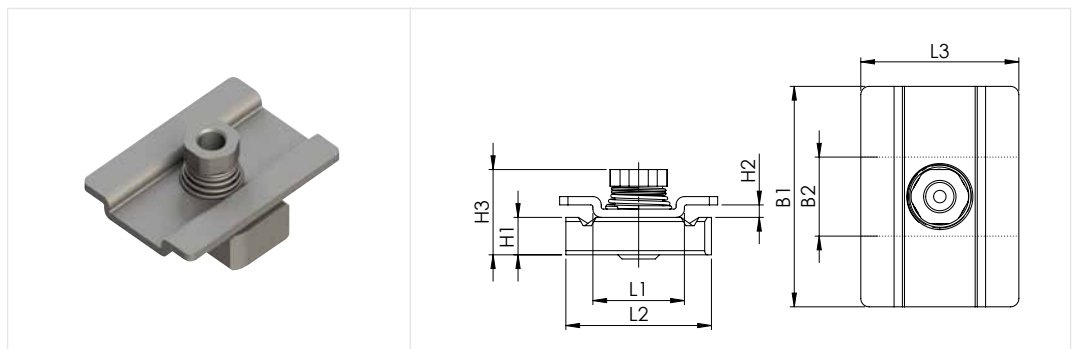

Schellengröße Clamp size	Befestigungsadapter Fixed adaptor												
	BA	L1	L2	L3	B1	B2	H1	H2	H3	d6			
1	BA-A/B1	22	35	38	16	19	6	3	19,5	M6			
2	BA-B2-3				53								
3	BA-B4-5				80						9	23,5	M8
4													
5													

Lieferbar: verzinkt und Edelstahl
Auch in UNC erhältlich
Available: galvanized and stainless steel
Also available in UNC



**BEFESTIGUNGSADAPTER FÜR SERIE C
FIXED ADAPTOR FOR SERIES C**

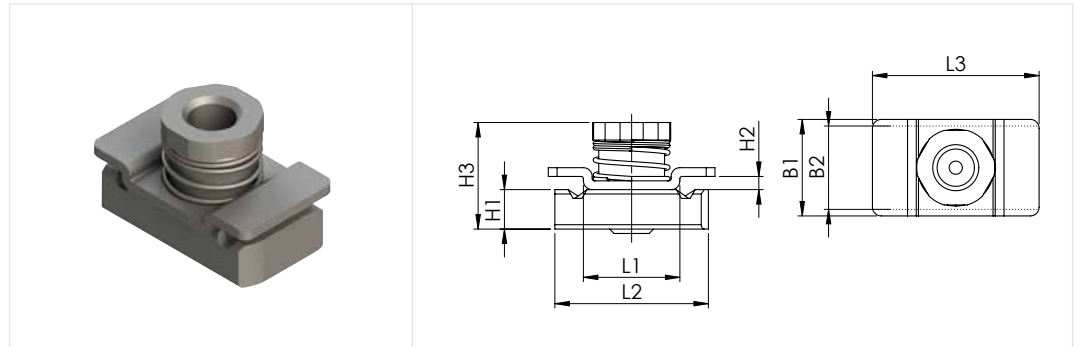

Schellengröße Clamp size	Befestigungsadapter Fixed adaptor									
	BA	L1	L2	L3	B1	B2	H1	H2	H3	d6
1	BA-C1-3	22	35	38	22	19	9	3	24,3	M10
2										
3	BA-C4			45	25				25,8	M12
4										

**EMPFOHLENE SCHRAUBENLÄNGEN BEI VERWENDUNG DES BEFESTIGUNGSADAPTERS BS FÜR DIE C-SERIE
RECOMMENDED SCREW LENGTHS WHEN USING FIXED ADAPTOR BA FOR SERIES C**

Schellengröße Clamp size	Sechskantschraube (mit Deckplatte) Hexagon head screw (with cover plate)	Innensechskantschraube (ohne Deckplatte) Hexagon socket head screw (without cover plate)	Aufbauschraube Stacking bolt
1	M10 x 40	M10 x 20 *	M10 x 20 *
2	M10 x 55 *	M10 x 35 *	M10 x 35 *
3	M10 x 65 *	M10 x 50 *	M10 x 50 *
4	M12 x 100	M12 x 75 *	M12 x 75 *

* bei Schrauben mit Sonderlängen (abweichend vom Katalog) Preis auf Anfrage
* for screws with special length (different from the catalog) price on request

**KOMPATIBILITÄT MIT PROFILSCHIENEN
COMPATIBILITY WITH CHANNEL RAILS**

Hilti (Schienensystem MQ für mittlere Belastung <i>Channel system MQ for medium load</i>)	Halfen (Mittelschwere Tragsysteme <i>Medium duty channel system</i>)	Unistrut®
MQ-21, MQ-21U, MQ-21D	HM 41/22, HL 41/22, HM 41/22 D	P1000, P1000T, P1001, P1001T
MQ-31,	HZM 41/22, HZL 41/22, HZM 41/22 D	P2000, P2000T
MQ-41, MQ-41U, MQ-41D	HM 41/41, HL 41/41, HM 41/41 D	P3300, P3300T10, P3301, P3301T10
MQ-52, MQ-52-72D	HZM 41/41, HZL 41/41, HZM 41/41 D	P4000, P4000T10
MQ-72, MQ-72U	HM 41/62, HL 41/62, HM 41/62 D	P5000T, P5001T, P5500T, P5501T
	HM 41/83, HL 41/83	

Zur Überprüfung der Kompatibilität mit Profilschienen anderer Hersteller wenden Sie sich bitte vor Anwendung an uns.
Please contact us to check compatibility with additional types of channel rails.

**GENERELLE MASSLICHE ANFORDERUNGEN AN PROFILSCHIENEN FÜR DEN EINSATZ DES BEFESTIGUNGSADAPTERS BA
BASIC DIMENSIONAL REQUIREMENTS FOR CHANNEL RAILS TO BE USED WITH FIXED ADAPTOR BA**

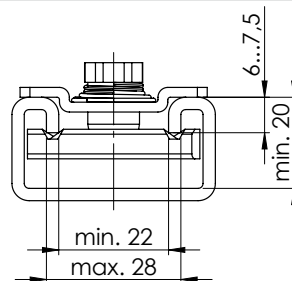

**BESTELLBEISPIEL
EXAMPLE FOR ORDER**

BA-A/B1/Zn
BA-B2-3/Mat.A4
BA-C1-3/Zn/UNC

BA - A/B1 / Zn

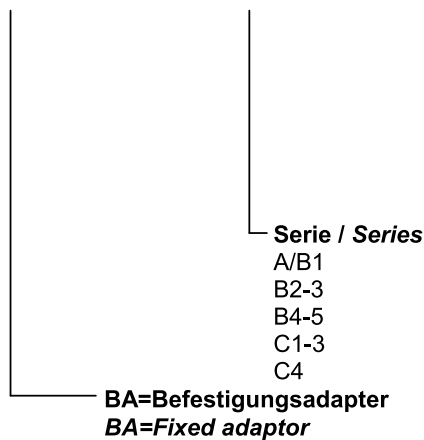

Merkmale / Features

Zn=verzinkt
Mat.A4=Edelstahl A4
UNC=UNC-Gewinde
Zn=zinc plated
Mat.A4=stainless steel A4
UNC=UNC thread

Lieferbar: verzinkt und Edelstahl
Auch in UNC erhältlich
*Available: galvanized and stainless steel
Also available in UNC*



Unbegrenzte Möglichkeiten:

Eine Schiene für alle

Montage von Elementen der Serie A, B und C auf TS-C Schiene

Unlimited possibilities:

One mounting rail for all

Assembly of series A, B and C components on TS-C mounting rail



Konstruktion

Neue Tragschienen-Muttern ermöglichen eine Montage der Rohrschellen unserer Serie A-, B- und C-Standardausführung auf Montageschienen der schweren Baureihe C.

Vorteil für Sie

Kombinieren Sie bewährte Elemente unserer verschiedenen Baureihen für eine Vielzahl neuer Anwendungsmöglichkeiten:

Eine Schiene, mehr Funktion!

Alle Metallteile auch in Edelstahl.

Design

New mounting rail-nuts make it possible to mount standard tube clamps of our series A, B and C, on the heavy duty mounting rail, series C.

Your advantage

Combine reliable and field-tested components of our various series for a multitude of new applicability:

One mounting rail – more functions!

Also available in stainless steel.

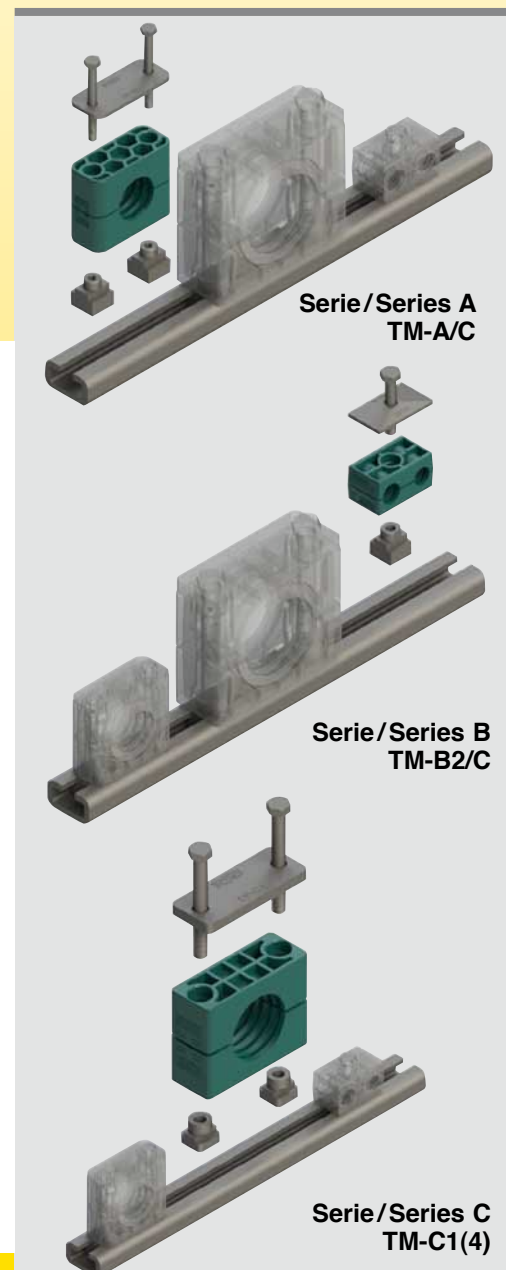

TRAGSCHIENEN-MUTTERN

Der einfachste Weg Rohrschellen DIN 3015 auf einer Tragschiene der schweren Baureihe zu montieren.

- Leichte Baureihe – Serie A
- Zweirohrschele – Serie B
- Schwere Baureihe – Serie C

Bestellzeichen: **TM-A/C**
 TM-B2/C
 TM-C1
 TM-C4

RAIL NUTS

The easiest way to mount DIN 3015 tube clamps on a rail our heavy duty series.

- Light construction – Series A
- Twin-tube clamps – Series B
- Heavy duty construction – Series C

Order codes: **TM-A/C**
 TM-B2/C
 TM-C1
 TM-C4

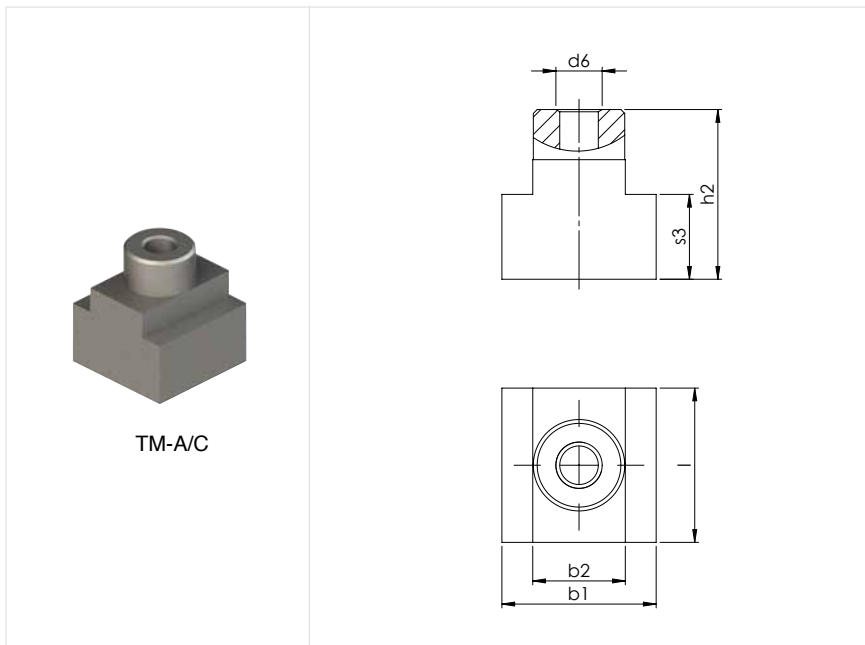

TM-A/C

Für Schellen Serie For clamps series	Bestellzeichen Order codes	d ₆	l	b ₁	b ₂	h ₂	s ₃
A / B1	TM-A/C	M 6	20	20	12	22	11
B2 – B5	TM-B2/C	M 8	20	20	12	22	11
C1 – C3	TM-C1	M 10	25	24	12	20	7
C4	TM-C4	M 12	25	24	12,5	23	8,5

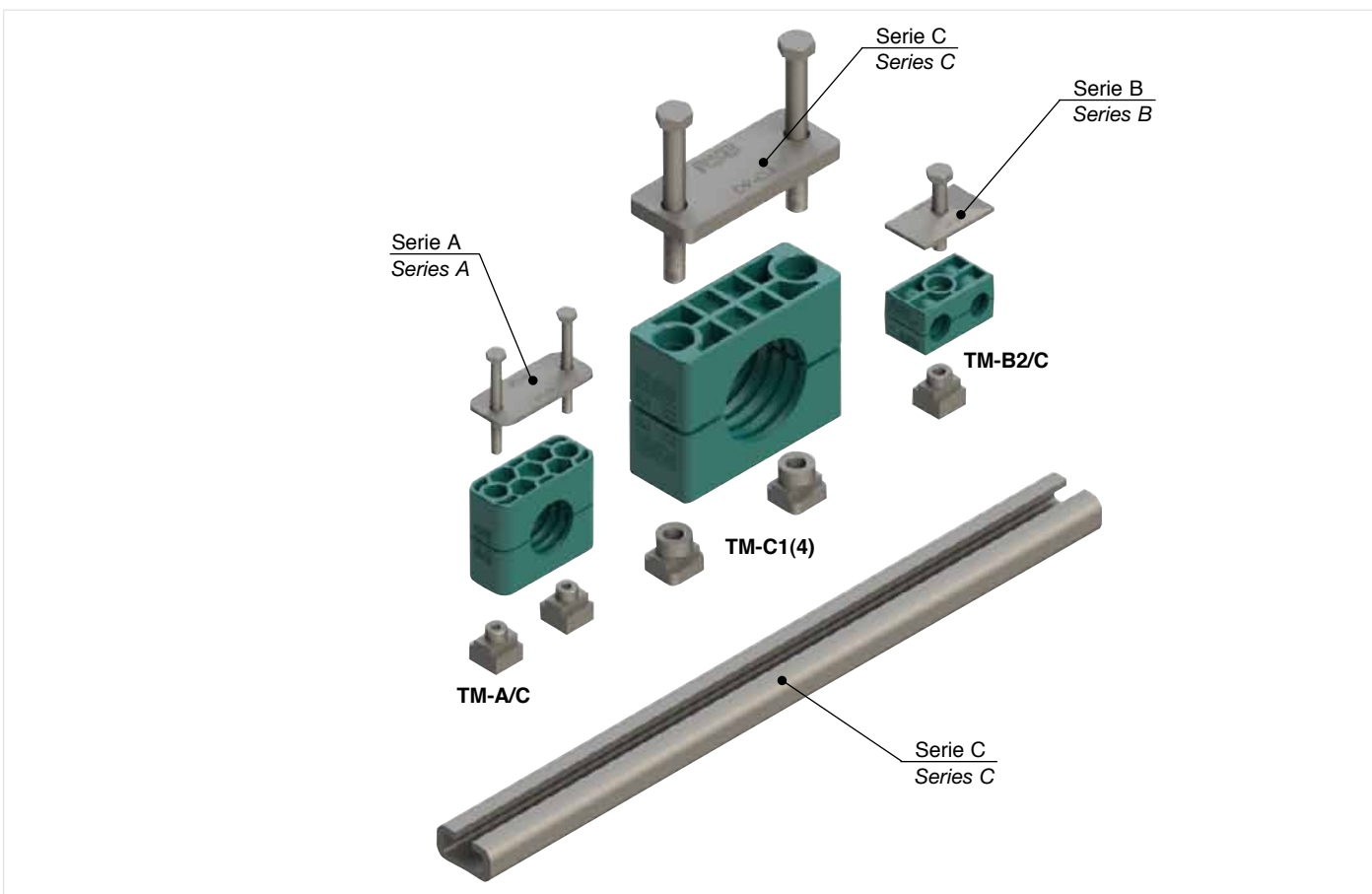

Montagebeispiele mit Tragschienen

Einfache Montage
Individuelle Zusammenstellungen
Vielseitige Einsetzbarkeit

Examples for the assembly with mounting rails

*Easily assembled
Individual combination
Versatile application*

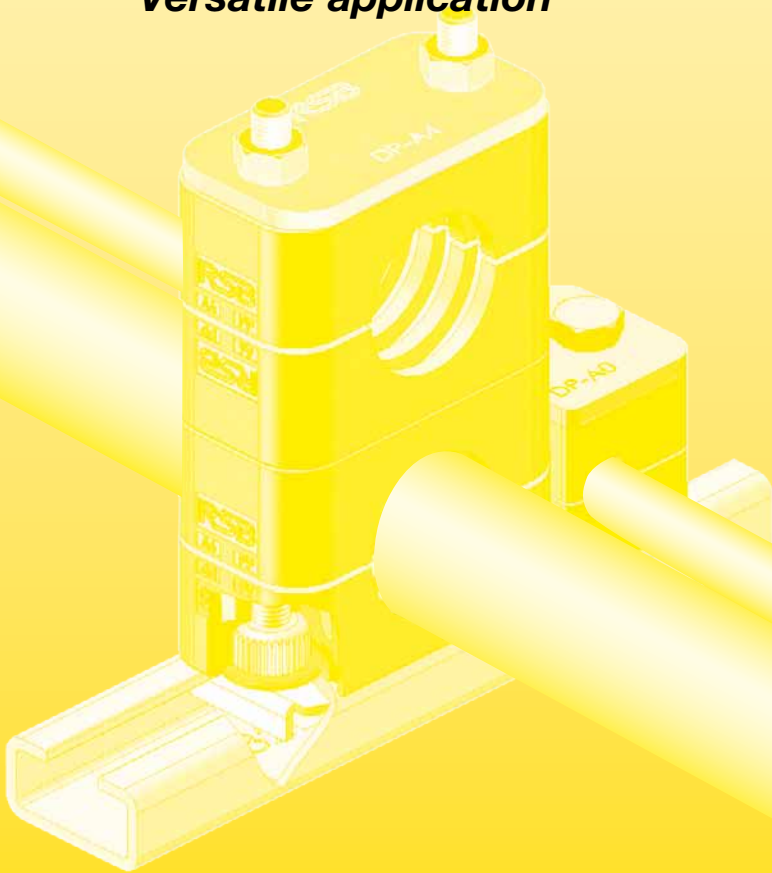

Rohrschellen mit Schalldämmeinlage

Tube Clamps with noise protection insert



Vibrationsdämmung und Körperschallentkopplung im System
Für jede Anwendung die richtige Lösung!

*The system for vibration insulation and structure-borne noise insulation
The suitable solution for each application!*

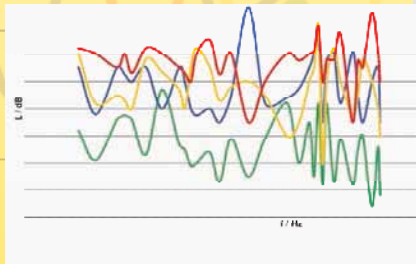

RCPR-330 RCPEE-330 RCVG-330 RCPEA-430

Vergleich des Dämmungsverhalten
verschiedener Rohrschellen
(schematisch)

*Comparison of the noise insulation
properties of different tube clamps
(schematic)*

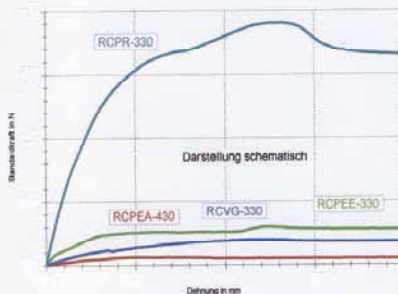

Vergleich der axialen Rohrhaltekraft
verschiedener Rohrschellen

*Comparison of the pipe shearing
force of different tube clamps*

Die Herstellung lärmloser Maschinen, Geräte
und Anlagen gewinnt durch das wachsende
Umweltbewusstsein immer mehr an Bedeutung.

Mit unserem Schalldämmungssystem

- Schellenkörper vollelastisch aus TPE
 - Rohrschellen mit Schalldämmeinlage EE/TPE
 - Rohrschellen mit Schalldämmeinlage EFA/TPE
- decken Sie alle Anwendungsbereiche ab.

*The production of quiet machines, devices and
equipment becomes more and more important
due to the growing environmental awareness.*

With our noise protection system

- Fully flexible Tube clamps TPE
 - Tube clamps with noise protection insert EE/TPE
 - Tube clamps with noise protection insert EFA/TPE
- you cover all fields of applications.



LEICHTBAUREIHE

Bestellzeichen für Schellenhälften:
Polypropylen **RAPE**
Polyamid 6 **RANE**

Bei Bedarf Standardkurzzeichen RAPE oder RAPEE in der Spalte „Serie A“ austauschen.

LIGHT CONSTR. SERIES

Order codes for clamp-halves:
Polypropylene **RAPE**
Polyamide 6 **RANE**

Replace standard abbreviation RAPE or RAPEE in column "Series A" as required.

SCHALLDÄMMEINLAGE

Bestellzeichen: EE-*
*mit Schellengröße und Rohraußen-
durchmesser ergänzen,
TPE 73° Shore

NOISE PROTECTION INSERT

Order code: EE-*
*complete with clamp size and outside tube
diameter,
TPE 73° Shore

Schellengröße Clamp size Serie A Series A	Rohr-AD mm O.D. mm	Serie A / Series A		Schalldämmeinlage Noise protection insert
		Schellenkörper für Einlage Tube clamp suitable for insert	Schellenkörper mit Schalldämmeinlage Tube clamp with noise protection insert	
4	6	RAPE-4	RAPEE-406	EE-206/406
	8		RAPEE-408	EE-208/408
	10		RAPEE-410	EE-210/410
	12		RAPEE-412	EE-212/412
	12,7		RAPEE-412,7	EE-212,7/412,7
	14		RAPEE-414	EE-214/414
	15		RAPEE-415	EE-215/415
	16		RAPEE-416	EE-216/416
	17,2		RAPEE-417,2	EE-217,2/417,2
	18		RAPEE-418	EE-218/418
	19		RAPEE-419	EE-219/419
5	20	RAPE-5	RAPEE-520	EE-520
	22		RAPEE-522	EE-522
	25		RAPEE-525	EE-525
	28		RAPEE-528	EE-528
	30		RAPEE-530	EE-530
6	20	RAPE-6	RAPEE-620	EE-320/620
	21,3		RAPEE-621,3	EE-321,3/621,3
	22		RAPEE-622	EE-322/622
	23		RAPEE-623	EE-323/623
	25		RAPEE-625	EE-325/625
	26,9		RAPEE-626,9	EE-326,9/626,9
	28		RAPEE-628	EE-328/628
	30		RAPEE-630	EE-330/630
	32		RAPEE-632	EE-332/632
6	35	RAPAE-6	RAPEE-635	EE-635
	38		RAPEE-638	EE-638
	42		RAPEE-642	EE-642
	45		RAPEE-645	EE-645

Achtung! Bei Schellen mit Schalldämmeinlage ist die Zuordnung von Durchmesser und Baugröße nicht identisch mit der Profil- bzw. glatten Ausführung.
Attention! For tube clamps with noise protection insert, the relation of diameter and size is not identical with the profile design or smooth design.



SCHWERE BAUREIHE

Bestellzeichen für Schellenhälften:
Polypropylen **RCPE**
Polyamid 6 **RCNE**

Bei Bedarf Standardkurzzeichen RCPE oder RCPEE in der Spalte „Serie C“ austauschen.

SCHALLDÄMMEINLAGE

Bestellzeichen: **EE-***
*mit Schellengröße und Rohraußen-
durchmesser ergänzen,
TPE 73° Shore

HEAVY SERIES

Order codes for clamp-halves:
Polypropylene **RCPE**
Polyamide 6 **RCNE**

Replace standard abbreviation RCPE or RCPEE in column "Series C" as required.

NOISE PROTECTION INSERT

Order code: **EE-***
*complete with clamp size and outside tube
diameter,
TPE 73° Shore

Schellengröße Clamp size Serie C Series C	Rohr-AD mm O.D. mm	Serie C / Series C		Schalldämmeinlage Noise protection insert
		Schellenkörper für Einlage Tube clamp suitable for insert	Schellenkörper mit Schalldämmeinlage Tube clamp with noise protection insert	
2	6	RCPE-2	RCPEE-206	EE-206/406
	8		RCPEE-208	EE-208/408
	10		RCPEE-210	EE-210/410
	12		RCPEE-212	EE-212/412
	12,7		RCPEE-212,7	EE-212,7/412,7
	14		RCPEE-214	EE-214/414
	15		RCPEE-215	EE-215/415
	16		RCPEE-216	EE-216/416
	17,2		RCPEE-217,2	EE-217,2/417,2
	18		RCPEE-218	EE-218/418
	19		RCPEE-219	EE-219/419
3	20	RCPE-3	RCPEE-320	EE-320/620
	21,3		RCPEE-321,3	EE-321,3/621,3
	22		RCPEE-322	EE-322/622
	23		RCPEE-323	EE-323/623
	25		RCPEE-325	EE-325/625
	26,9		RCPEE-326,9	EE-326,9/626,9
	28		RCPEE-328	EE-328/628
	30		RCPEE-330	EE-330/630
	32		RCPEE-332	EE-332/632
	4		32	RCPE-4
33,7		RCPEE-433,7	EE-433,7	
35		RCPEE-435	EE-435	
38		RCPEE-438	EE-438	
40		RCPEE-440	EE-440	
42		RCPEE-442	EE-442	
45,5		RCPEE-445,5	EE-445,5	
48		RCPEE-448	EE-448	
51		RCPEE-451	EE-451	
53,4		RCPEE-453,4	EE-453,4	
56,4		RCPEE-456,4	EE-456,4	
60,3		RCPEE-460,3	EE-460,3	
5	57	RCPE-5	RCPEE-557	EE-557
	60,3		RCPEE-560,3	EE-560,3
	63,5		RCPEE-563,5	EE-563,5
	65		RCPEE-565	EE-565
	70		RCPEE-570	EE-570
	73		RCPEE-573	EE-573
	76,1		RCPEE-576,1	EE-576,1

Achtung! Bei Schellen mit Schalldämmeinlage ist die Zuordnung von Durchmesser und Baugröße nicht identisch mit der Profil- bzw. glatten Ausführung.
Attention! For tube clamps with noise protection insert, the relation of diameter and size is not identical with the profile design or smooth design.



SCHWERE BAUREIHE

Bestellzeichen für Schellenhälften:
Polypropylen **RCPE**
Polyamid 6 **RCNE**

Bei Bedarf Standardkurzzeichen RCPE oder RCPEE in der Spalte „Serie C“ austauschen.

SCHALLDÄMMEINLAGE

Bestellzeichen: EE-*
*mit Schellengröße und Rohraußen-
durchmesser ergänzen,
TPE 73° Shore

HEAVY SERIES

Order codes for clamp-halves:
Polypropylene **RCPE**
Polyamide 6 **RCNE**

Replace standard abbreviation RCPE or RCPEE in column "Series C" as required.

NOISE PROTECTION INSERT

Order code: EE-*
*complete with clamp size and outside tube
diameter,
TPE 73° Shore

Schellengröße Clamp size Serie C Series C	Rohr-AD mm O.D. mm	Serie C / Series C		Schalldämmeinlage Noise protection insert
		Schellenkörper für Einlage Tube clamp suitable for insert	Schellenkörper mit Schalldämmeinlage Tube clamp with noise protection insert	
6	80	RCPE-6	RCPEE-680	EE-680
	82,5		RCPEE-682,5	EE-682,5
	88,9		RCPEE-688,9	EE-688,9
	100		RCPEE-6100	EE-6100
	101,6		RCPEE-6101,6	EE-6101,6
7	101,6	RCPE-7	RCPEE-7101,6	EE-7101,6
	108		RCPEE-7108	EE-7108
	114,3		RCPEE-7114,3	EE-7114,3
	127		RCPEE-7127	EE-7127
	133		RCPEE-7133	EE-7133

Achtung! Bei Schellen mit Schalldämmeinlage ist die Zuordnung von Durchmesser und Baugröße nicht identisch mit der Profil- bzw. glatten Ausführung.
Attention! For tube clamps with noise protection insert, the relation of diameter and size is not identical with the profile design or smooth design.



LEICHTE BAUREIHE

Bestellzeichen für Schellenhälften:
 Polypropylen **RAPE**
 Polyamid **RANE**

Schellengröße A6 ab Ø 22:
RAPAE
RANAE

Bei Bedarf Standardkurzzeichen RAPE/RAPAE oder RAPEA in der Spalte „Serie A“ austauschen.

LIGHT CONSTR. SERIES

Order codes for clamp-halves:
 Polypropylene **RAPE**
 Polyamide 6 **RANE**

Clamp size A6 from Ø 22:
RAPAE
RANAE

Replace standard abbreviation RAPE/RAPAE or RAPEA in column "Series A" as required.

SCHALLDÄMMEINLAGE

Bestellzeichen: **EFA-***

*mit Schellengröße und Rohraußen-
durchmesser ergänzen,
TPE 73° Shore

NOISE PROTECTION INSERT

Order code: **EFA-***

*complete with clamp size and outside tube
diameter,
TPE 73° Shore

Schellengröße Clamp size Serie A Series A	Rohr-AD mm O.D. mm	Serie A / Series A		Schalldämmeinlage Noise protection insert
		Schellenkörper für Einlage Tube clamp suitable for insert	Schellenkörper mit Schalldämmeinlage Tube clamp with noise protection insert	
4	10	RAPE-4	RAPEA-410	EFA-410
5	10 12 15	RAPE-5	RAPEA-510 RAPEA-512 RAPEA-515	EFA-510 EFA-512 EFA-515
6	10 12 15 18 20	RAPE-6	RAPEA-610 RAPEA-612 RAPEA-615 RAPEA-618 RAPEA-620	EFA-610 EFA-612 EFA-615 EFA-618 EFA-620
6	22 25 28 30	RAPAE-6	RAPEA-622 RAPEA-625 RAPEA-628 RAPEA-630	EFA-622 EFA-625 EFA-628 EFA-630

Achtung! Bei Schellen mit Schalldämmeinlage ist die Zuordnung von Durchmesser und Baugröße nicht identisch mit der Profil- bzw. glatten Ausführung.
Attention! For tube clamps with noise protection insert, the relation of diameter and size is not identical with the profile design or smooth design.



SCHWERE BAUREIHE

Bestellzeichen für Schellenhälften:
Polypropylen **RCPE**
Polyamid 6 **RCNE**

Bei Bedarf Standardkurzzeichen RCPE oder RCPEA in der Spalte „Serie C“ austauschen.

SCHALLDÄMMEINLAGE

Bestellzeichen: **EFA-***

*mit Schellengröße und Rohraußen-durchmesser ergänzen, TPE 73° Shore

HEAVY SERIES

Order codes for clamp-halves:
Polypropylene **RCPE**
Polyamide 6 **RCNE**

Replace standard abbreviation RCPE or RCPEA in column "Series C" as required.

NOISE PROTECTION INSERT

Order code: **EFA-***

*complete with clamp size and outside tube diameter, TPE 73° Shore

Schellengröße Clamp size Serie C Series C	Rohr-AD mm O.D. mm	Serie C / Series C		Schalldämmeinlage Noise protection insert
		Schellenkörper für Einlage Tube clamp suitable for insert	Schellenkörper mit Schalldämmeinlage Tube clamp with noise protection insert	
3	10	RCPE-3	RCPEA-310	EFA-310
	12		RCPEA-312	EFA-312
	15		RCPEA-315	EFA-315
	18		RCPEA-318	EFA-318
	20		RCPEA-320	EFA-320
4	22	RCPE-4	RCPEA-422	EFA-422
	25		RCPEA-425	EFA-425
	28		RCPEA-428	EFA-428
	30		RCPEA-430	EFA-430
	35		RCPEA-435	EFA-435
5	35	RCPE-5	RCPEA-535	EFA-535
	38		RCPEA-538	EFA-538
	42		RCPEA-542	EFA-542
	48,3		RCPEA-548,3	EFA-548,3
	60,3		RCPEA-560,3	EFA-560,3
6	76,1	RCPE-6	RCPEA-676,1	EFA-676,1
	88,9		RCPEA-688,9	EFA-688,9
7	114,3	RCPE-7	RCPEA-7114,3	EFA-7114,3

Achtung! Bei Schellen mit Schalldämmeinlage ist die Zuordnung von Durchmesser und Baugröße nicht identisch mit der Profil- bzw. glatten Ausführung.

Attention! For tube clamps with noise protection insert, the relation of diameter and size is not identical with the profile design or smooth design.

Die vollelastische Rohrschelle

Optimale Geräusch- und Vibrationsdämmung

The fully flexible tube clamp

Optimum sound insulation and vibration dampening

Der Grundstoff

Die vollelastischen Rohrschellen werden aus thermoplastischem Kautschuk gefertigt.

Die Vorteile

Entscheidende Verbesserungen hinsichtlich der Geräuschdämmung und im Vibrationsverhalten. Einfache Befestigung auch empfindlicher Rohr- und Schlauchinstallationen. Die wesentlichen Eigenschaften dieses Materials liegen deutlich über denen vergleichbarer vulkanisierter Gummierzeugnisse.

Die Ausführungen

Die Innenflächen sind glatt oder gerippt. Eine sinnvolle Schraubensicherung garantiert auch bei der Vollgummiausführung einwandfreie Verbindungen – ein selbstständiges Lösen ist unmöglich! Die Anschweißplatten, Deckplatten und Schrauben sind auch in Edelstahl rostfrei lieferbar.

Lieferbare Abmessungen entnehmen Sie bitten dem Standardprogramm DIN 3015.

The primary material

The fully flexible tube clamps are made out of thermoplastic caoutchouc.

The advantages

Decisive improvements regarding noise insulation and vibration behavoiur. Easy securing also of sensitive tube and pipe installations. The essential qualities of this material are appreciably higher than those of comparable vulcanized rubber products.

The constructions details

The internal surface are smooth or grooved. A useful screw safety-device guarantees perfect connections also for the solid rubber construction – therefore making a self-acting loosening impossible! The welding plates, covers and screws are also available in stainless steel.

Measurement please order at the standard range DIN 3015.

Geräusch- und vibrationsarm

Low noise and vibration level

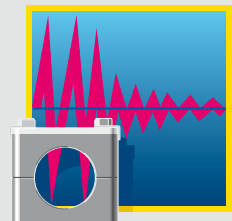

Witterungs- und alterungsbeständig

Weather-proof and brittle-resistant



Formstabilität bei hoher Elastizität

Shape stability with high elasticity



Beständig gegen viele Chemikalien

Resistant against many chemicals



Breiter Temperatur-Einsatzbereich

Wide temperature deployment area

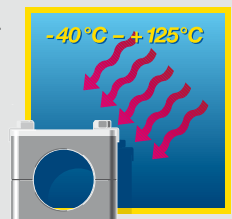

Multischellen *Multiclamps*

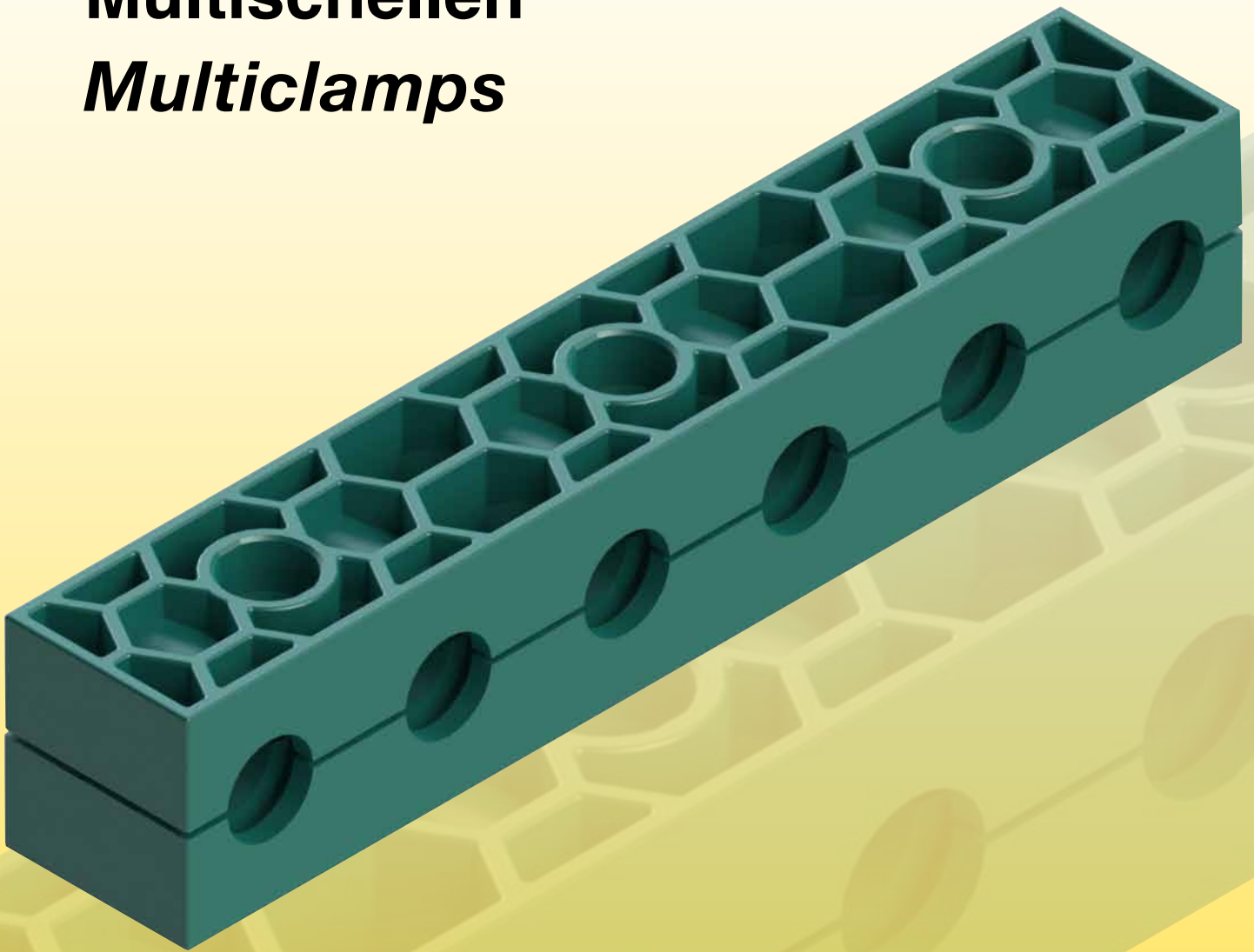

Bestellzeichen für Schellenhälften:

Polypropylen innen glatt **RAPRM**
RAPGM²⁾
Polyamid 6 innen glatt **RANRM**
RANGM²⁾
Vollgummi **RAVGM**^{2) 3)}

Order codes for clamp-halves:

Polypropylene inside smooth **RAPRM**
RAPGM²⁾
Polyamide 6 inside smooth **RANRM**
RANGM²⁾
Rubber **RAVGM**^{2) 3)}

Bei Bedarf Standardkurzzeichen RAPRM in der Spalte „Schellenhälften“ austauschen.

Replace standard abbreviation RAPRM in column "clamp-halves" as required.

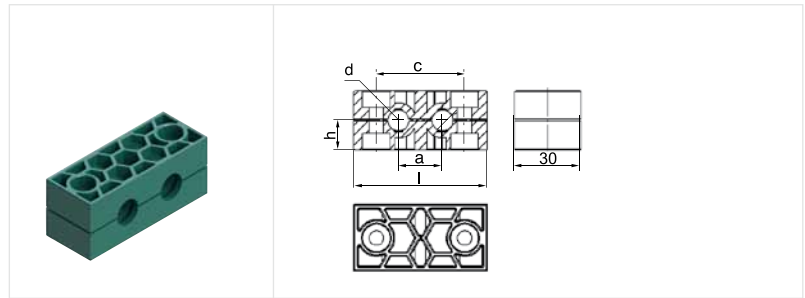

Schellengröße Clamp size	Rohr-AD mm O.D. mm	Anzahl der Rohre Number of tubes	1 Stück / 2 Schellenhälften 1 part / 2 clamp-halves RAPRM	2 Schellenhälften 2 clamp-halves RAPRM-...				Befestigungsschrauben Fastening screws B
				a	c	h	l	
1	6	2	RAPRM-1xxxB2	20	40	13,5	60,5	2
	6,4							
	8							
	9,5							
	10							
2	10	2	RAPRM-2xxxB2	29	58	16,5	78,5	2
	12							
	12,7							
	13,5							
	14							
	15							
	16							
17,2								
3	18	2	RAPRM-3xxxB2	36	72	18,5	92,5	2
	15							
	16							
	17,2							
	18							
	19							
	20							
	21,3							
	22							
	23							
25								
25,4								

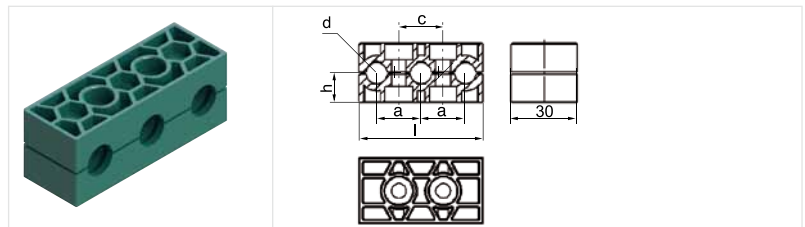

Schellengröße Clamp size	Rohr-AD mm O.D. mm	Anzahl der Rohre Number of tubes	1 Stück / 2 Schellenhälften 1 part / 2 clamp-halves RAPRM	2 Schellenhälften 2 clamp-halves RAPRM-...				Befestigungsschrauben Fastening screws B
				a	c	h	l	
1	6	3	RAPRM-1xxxB3	20	20	13,5	56	2
	6,4							
	8							
	9,5							
	10							
2	10	3	RAPRM-2xxxB3	29	29	16,5	85	2
	12							
	12,7							
	13,5							
	14							
	15							
	16							
17,2								
3	18	3	RAPRM-3xxxB3	36	36	18,5	106	2
	15							
	16							
	17,2							
	18							
	19							
	20							
	21,3							
	22							
	23							
25								
25,4								

²⁾ohne Vorspannung

³⁾Bei Montage von Vollgummi-Schellen sind Deckplatten, Sechskantschrauben und Sicherungsscheiben zu verwenden

²⁾without prestress

³⁾When assembling solid rubber tube clamps, cover plates, hexagon screws and locking washers must be used

Bestellzeichen

für Schellenhälften:

Polypropylen innen glatt **RAPRM**
 Polypropylen innen glatt **RAPGM²⁾**
 Polyamid 6 innen glatt **RANRM**
 Polyamid 6 innen glatt **RANGM²⁾**
 Vollgummi **RAVGM^{2) 3)}**

Order codes

for clamp-halves:

Polypropylene inside smooth **RAPRM**
 Polypropylene inside smooth **RAPGM²⁾**
 Polyamide 6 inside smooth **RANRM**
 Polyamide 6 inside smooth **RANGM²⁾**
 Rubber **RAVGM^{2) 3)}**

Bei Bedarf Standardkurzzeichen RAPRM in der Spalte „Schellenhälften“ austauschen.

Replace standard abbreviation RAPRM in column "clamp-halves" as required.

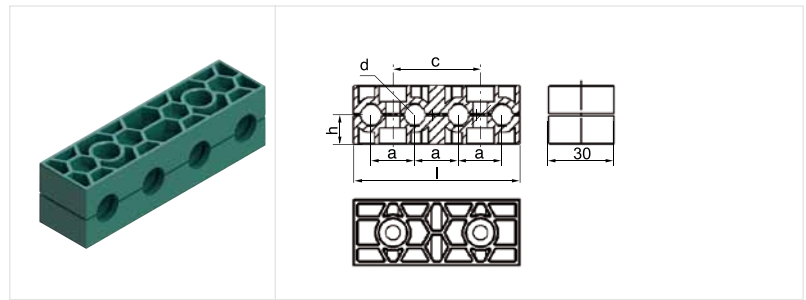

Schellengröße Clamp size	Rohr-AD mm O.D. mm	Anzahl der Rohre Number of tubes	1 Stück / 2 Schellenhälften 1 part / 2 clamp-halves RAPRM	2 Schellenhälften 2 clamp-halves RAPRM-...				Befestigungsschrauben Fastening screws B
				a	c	h	l	
1	6	4	RAPRM-1xxxB4	20	40	13,5	76	2
	6,4							
	8							
	9,5							
	10							
2	10	4	RAPRM-2xxxB4	29	58	16,5	114	2
	12							
	12,7							
	13,5							
	14							
	15							
	16							
17,2								
3	18	4	RAPRM-3xxxB4	36	72	18,5	142	2
	15							
	16							
	17,2							
	18							
	19							
	20							
	21,3							
	22							
	23							
	25							
25,4								

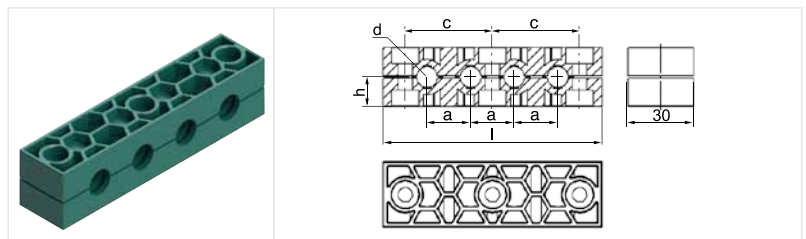

Schellengröße Clamp size	Rohr-AD mm O.D. mm	Anzahl der Rohre Number of tubes	1 Stück / 2 Schellenhälften 1 part / 2 clamp-halves RAPRM	2 Schellenhälften 2 clamp-halves RAPRM-...				Befestigungsschrauben Fastening screws C
				a	c	h	l	
1	6	4	RAPRM-1xxxC4	20	40	13,5	100,5	3
	6,4							
	8							
	9,5							
	10							
2	10	4	RAPRM-2xxxC4	29	58	16,5	136,5	3
	12							
	12,7							
	13,5							
	14							
	15							
	16							
17,2								
3	18	4	RAPRM-3xxxC4	36	72	18,5	164,5	3
	15							
	16							
	17,2							
	18							
	19							
	20							
	21,3							
	22							
	23							
	25							
25,4								

²⁾ohne Vorspannung

³⁾Bei Montage von Vollgummi-Schellen sind Deckplatten, Sechskantschrauben und Sicherungsscheiben zu verwenden

²⁾without prestress

³⁾When assembling solid rubber tube clamps, cover plates, hexagon screws and locking washers must be used

Bestellzeichen

für Schellenhälften:

Polypropylen **RAPRM**
innen glatt **RAPGM²⁾**
Polyamid 6 **RANRM**
innen glatt **RANGM²⁾**
Vollgummi **RAVGM^{2) 3)}**

Order codes

for clamp-halves:

Polypropylene **RAPRM**
inside smooth **RAPGM²⁾**
Polyamide 6 **RANRM**
inside smooth **RANGM²⁾**
Rubber **RAVGM^{2) 3)}**

Bei Bedarf Standardkurzzeichen RAPRM in der Spalte „Schellenhälften“ austauschen.

Replace standard abbreviation RAPRM in column "clamp-halves" as required.

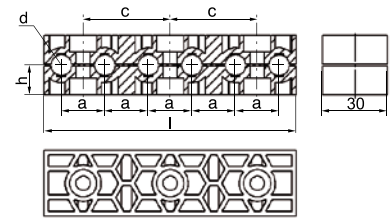

Schellengröße Clamp size	Rohr-AD mm O.D. mm	Anzahl der Rohre Number of tubes	1 Stück / 2 Schellenhälften 1 part / 2 clamp-halves RAPRM	2 Schellenhälften 2 clamp-halves RAPRM-...				Befestigungsschrauben Fastening screws C
				a	c	h	l	
1	6	6	RAPRM-1xxxC6	20	40	13,5	116	3
	6,4							
	8							
	9,5							
	10							
2	10	6	RAPRM-2xxxC6	29	58	16,5	172	3
	12							
	12,7							
	13,5							
	14							
	15							
	16							
17,2								
3	18	6	RAPRM-3xxxC6	36	72	18,5	214	3
	15							
	16							
	17,2							
	18							
	19							
	20							
	21,3							
	22							
	23							
25								
25,4								

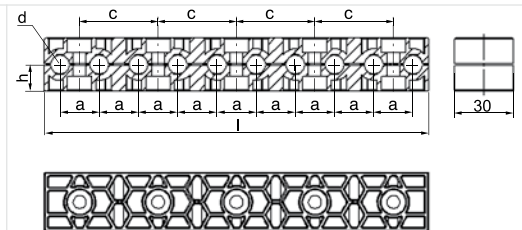

Schellengröße Clamp size	Rohr-AD mm O.D. mm	Anzahl der Rohre Number of tubes	1 Stück / 2 Schellenhälften 1 part / 2 clamp-halves RAPRM	2 Schellenhälften 2 clamp-halves RAPRM-...				Befestigungsschrauben Fastening screws E
				a	c	h	l	
1	6	10	RAPRM-1xxxE10	20	40	13,5	196	5
	6,4							
	8							
	9,5							
	10							
2	10	10	RAPRM-2xxxE10	29	58	16,5	288	5
	12							
	12,7							
	13,5							
	14							
	15							
	16							
17,2								
3	18	10	RAPRM-3xxxE10	36	72	18,5	358	5
	15							
	16							
	17,2							
	18							
	19							
	20							
	21,3							
	22							
	23							
25								
25,4								

²⁾ohne Vorspannung

³⁾Bei Montage von Vollgummi-Schellen sind Deckplatten, Sechskantschrauben und Sicherungsscheiben zu verwenden

²⁾without prestress

³⁾When assembling solid rubber tube clamps, cover plates, hexagon screws and locking washers must be used

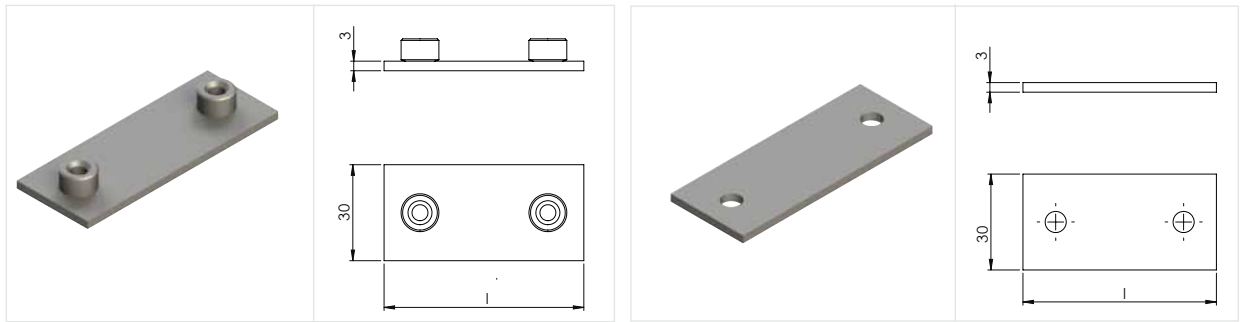

Schellengröße Clamp size	Anschweißplatte Weld plate APM-A						Deckplatte Cover plate DPM-A					
	B2	B3	B4	C4	C6	E10	B2	B3	B4	C4	C6	E10
1	62,5	58	78	102,5	118	198	60,5	56	76	100,5	116	196
2	80,5	87	116	138,5	174	300	78,5	85	114	136,5	172	288
3	94,5	108	144	166,5	216	360	92,5	106	142	164,5	214	358

BESTELLBEISPIEL
EXAMPLE FOR ORDER

RAPRM-1xx/B2
RAPRM-106/8/B2
RAPRM-315/21,3/25,4/B3

R A P R M - 1 0 6 / B 4

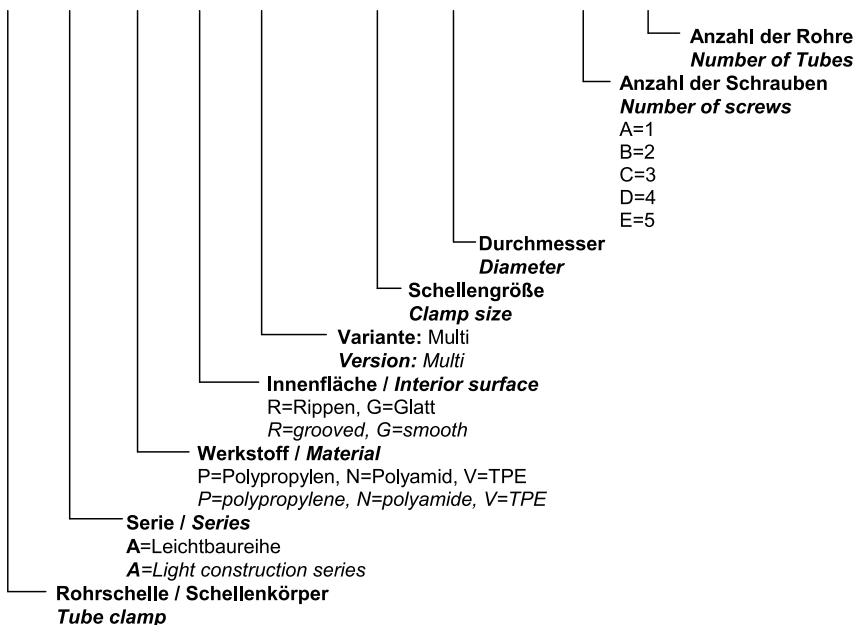

Metallteile in Edelstahl lieferbar.
All metal parts available in stainless steel.



Rohrschelle Serie O

Die preiswerte Lösung für Kabel und Schläuche

Tube clamp series O

The low-cost solution for cables and hoses



- schnelle Montage
- geringer Platzbedarf
- Deckplatte sorgt für stabile Befestigung
- sichere Klemmung der Rohre durch Vorspannung
- verschiedene Rohrdurchmesser kombinierbar
- Befestigung mit Schrauben
- besonders geeignet für Kabel, Schläuche, Gas- und Ölleitungen, Schmierleitungen
- Metallteile auch in Edelstahl lieferbar

- quick assembly
- space-saving
- Cover plate provides for stable fixing
- secure clamping of tubes due to pre-clamping
- different tube diameters combinable
- Fixing with screws
- particularly suitable for cables, hoses, gas and oil pipes, lubricating lines
- Metal parts also available in stainless steel

Rohrschelle Serie O
platzsparend und flexibel
von Ø 6 mm bis 22 mm

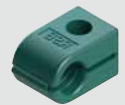

*Tube clamp series O
space-saving and flexible
from Ø 6 mm to 22 mm*

Doppel-Rohrschelle
Serie O mit gleichen
Durchmessern
von Ø 6 mm bis 22 mm

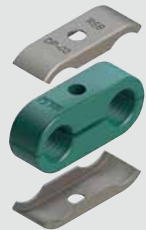

*Double-tube clamp series O
with same diameters
from Ø 6 mm to 22 mm*

Doppel-Rohrschelle Serie O
mit unterschiedlichen
Durchmessern von
Ø 6 mm bis 22 mm

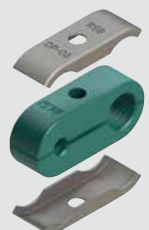

*Double-tube clamp
series O with different
diameters from
Ø 6 mm to 22 mm*



ROHRSCHELLE SERIE O

Bestellzeichen:

Polypropylen

ROP-*

Polyamid

RON-*

*ergänzen mit Größe und Durchmesser
(z.B. ROP-106)

Verpackungseinheiten: 100 Stück

Anwendungsbereiche:

- Drucklufttechnik
- Fahrzeugbau
- Maschinenbau
- Mess- und Regeltechnik
- Schiffsbau
- geeignet für Kabel und Schläuche

TUBE CLAMP SERIES O

Order Codes:

Polypropylene

ROP-*

Polyamide

RON-*

*supplement with size and tube Ø mm
(e.g. ROP-106)

Packing standard: 100 pieces

Areas of application:

- Pneumatics
- Automotive Technology
- Machine tool industry
- Lubrication
- Naval Technology
- suitable for cables and hoses

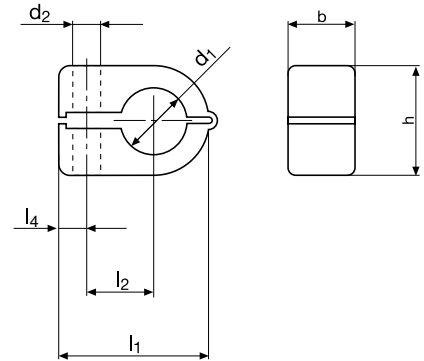

Schellengröße Clamp size	Rohr-Ø d ₁ / Tube Ø d ₁			l ₁	l ₂	l ₄	b	h	d ₂
	mm O.D. mm	Rohrzoll Tube NB	Inch Inch						
1	6		1/4	23	9	7	14,5	13,5	6,5
	6,4								
	8								
2	8	G 1/8	3/8	27	11	7	14,5	18,5	6,5
	9,5								
	10		1/2						
	12								
12,7									
3	10	G 1/8	1/2	34	15	7	14,5	23,5	6,5
	12								
	12,7	G 1/4							
	13,5								
	14								
	15								
16	5/8								
4	14	G 3/8	5/8	40	19	6	14,5	30,5	6,5
	15								
	16								
	17,2								
	18	G 1/2	3/4						
	19								
	20								
	21,3								
22									

DOPPEL-ROHRSCHELLE SERIE O

Bestellzeichen:

Polypropylen **ROPD-***
 Polyamid **ROND-***
 *ergänzen mit Größe und Durchmesser (z.B. ROPD-106),
 unterschiedliche Durchmesser auf Anfrage

Deckplatte: **DP-O***

*ergänzen mit Größe
Material: Stahl verzinkt (Edelstahl auf Anfrage)

Verpackungseinheiten: 100 Stück

Anwendungsbereiche:

- Drucklufttechnik
- Fahrzeugbau
- Maschinenbau
- Mess- und Regeltechnik
- Schiffsbau
- geeignet für Kabel und Schläuche



DOUBLE-TUBE CLAMP SERIES O

Order Codes:

Polypropylene **ROPD-***
 Polyamide **ROND-***
 *supplement with size and tube Ø mm (e.g. ROPD-106),
 different diameters on request

Cover plate: **DP-O***

*supplement with size
Material: Galvanized steel (Stainless steel upon request)

Packing standard: 100 pieces

Areas of application:

- Pneumatics
- Automotive Technology
- Machine tool industry
- Lubrication
- Naval Technology
- suitable for cables and hoses

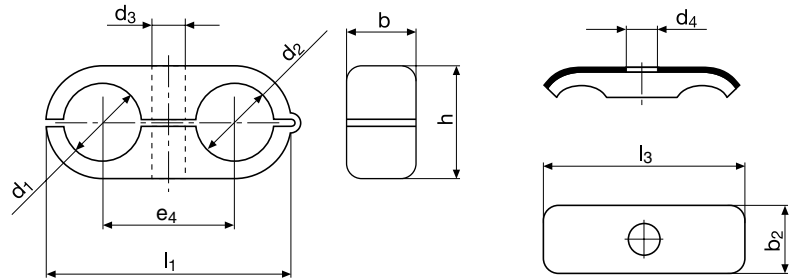

Schellengröße Clamp size	Rohr-Ø d ₁ / Tube Ø d ₁			l ₁	e ₄	b	h	d ₃	l ₃	b ₂	d ₄	
	mm O.D. mm	Rohrzoll Tube NB	Inch Inch									
1	6		1/4	32	18	14,5	13,5	6,5	29	16,3	6,5	
	6,4											
	8											
2	8	G 1/8	3/8	41	22	14,5	18,5	6,5	40	16,3	6,5	
	9,5											
	10 12 12,7											1/2
3	10	G 1/8	1/2	54	30	14,5	23,5	6,5	50,5	16,5	6,5	
	12,7											
	13,5	G 1/4	5/8									
	14											
	15 16											
4	14	G 3/8	5/8	69	38	14,5	30,5	6,5	63	16,5	6,5	
	15											
	16											
	17,2	G 1/2	3/4									
	18											
	19											
	20											
21,3 22												

Metalteile in Edelstahl lieferbar.
 All metal parts available in stainless steel.



Rohrbefestigung auf einem Zylinder

Rohrlager – Adapter – Klammer – Spannband

Tube fastening on a cylinder

Tube support – Adaptor –
Clip – Worm thread clamps

Rohrlager, Adapter, Klammer und Spannband sind als System ausgelegt.

Als Einzelteil oder in Kombination lassen sich praxisbezogen unterschiedliche Montagesituationen realisieren.

Berücksichtigt werden hierbei:

- Montage von Rohren oder Schläuchen auf Hydraulik-Zylindern
- unterschiedliche Rohr- oder Schlauch-Durchmesser
- unterschiedliche Rohrabstände zum Zylinder
- die Montage mehrerer Rohrlager für unterschiedliche Rohrdurchmesser

The complete system consists of the following individual components:

Tube support, adaptor, clip and worm thread clamps. Practical solutions for many different assembly situations can be found by either using an individual component or by combining all the components.

For example:

- Assembly of tubes or hoses on hydraulic cylinder
- different tube or hose diameters
- different distances between tubes and cylinder
- the assembly of several tube supports for different tube diameters

Die Montage:
Das „Clip+Fertig“-Prinzip!

Assembly:
The „Clip+Ready“-
System!

1.

Einzel-Montage
Rohrlager ohne Adapter

Single assembly
Tube support without adaptor

2.

Mehrfach-Montage
Rohrlager mit Klammer

Multiple assembly
Tube support with clip

3.

Aufbau-Montage
Rohrlager mit Adapter

Stacking assembly
Tube support with adaptor



	Bild / Figure 1	Bild / Figure 2	Bild / Figure 3
Montage auf Hydr.-Zylinder	Einzelmontage Rohrlager ohne Adapter	Montage mehrerer Rohrlager mit Klammer ohne Adapter	Montage mehrerer Rohrlager für verschiedene Rohr-Ø mit Klammer und Adapter
Assembly hydr. cylinder	Single-part assembly Tube support without adaptor	Assembly several tube supports with clip without adaptor	Assembly several tube supports with clip adaptors
Zylinder / Cylindre Ø	min. Ø 90 mm	min. Ø 100 mm	min. Ø 220 mm

ROHRLAGER

Bestellzeichen: RLP

Material: Polypropylen

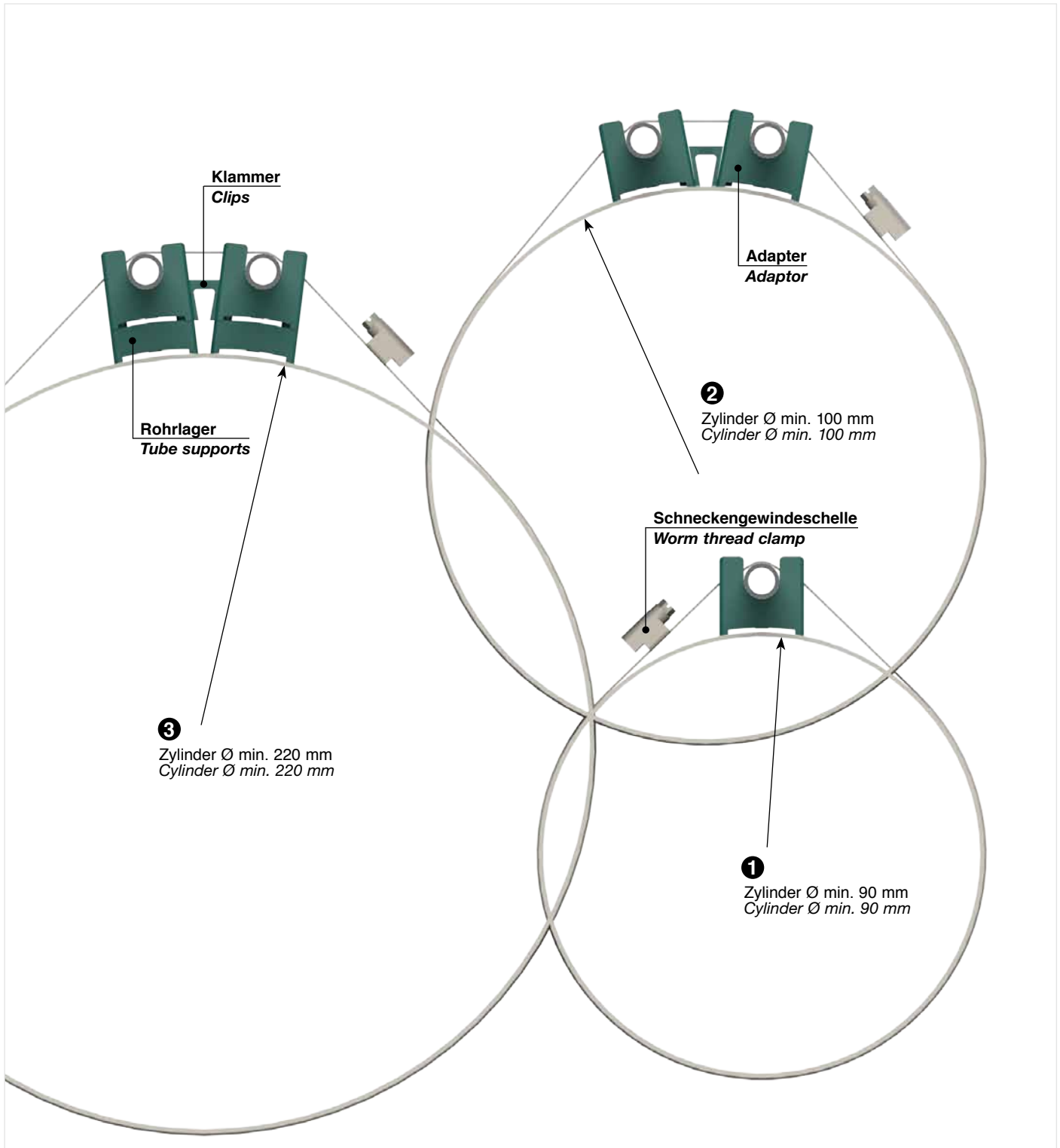
Mit dem Rohrlager RLP werden Rohre oder Schläuche unter Verwendung einer Schneckengewindeschelle (Spannband) auf Hydraulik-Zylinder montiert.

Siehe Bild 1

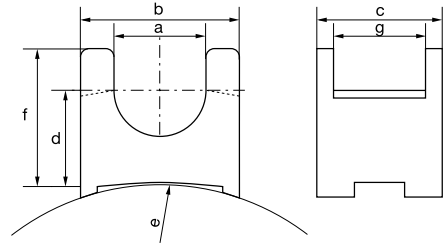
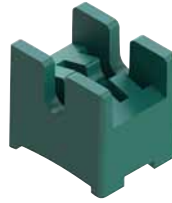

TUBE SUPPORT

Order code: RLP

Material: Polypropylene

With the RLP tube support, tubes or hoses can be fitted on hydraulic cylinders by using a worm thread clamp.

See figure 1

Rohr-Ø Tube Ø mm	Bestellzeichen Order Codes	a	b	c	d	e	f	g
8	RLP-8	8						
10	RLP-10	10						
12	RLP-12	12						
15	RLP-15	15						
16	RLP-16	16	38	30	21	R 110	32	22
18	RLP-18	18						
20	RLP-20	20						
22	RLP-22	22						
25	RLP-25	25						

ADAPTER

Bestellzeichen: ADP

Material: Polypropylen

Der Adapter ADP wird unter das Rohrlager geclippt, um größere Rohrabstände zum Zylinder zu erzielen.

Siehe Bild 3

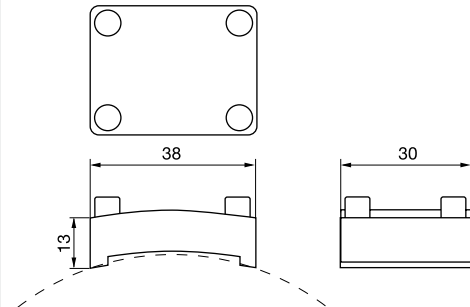

ADAPTOR

Order code: ADP

Material: Polypropylene

The ADP adaptor is clipped beneath the tube support in order to get a bigger distance between the tube and the cylinder.

See figure 3

KLAMMER

Bestellzeichen: KLP

Material: Polypropylen

Mit der Klammer KLP können Rohrlager zusammengefasst werden, um eine Montage von mehreren Rohren oder Schläuchen zu erleichtern.

Siehe Bild 2 und 3

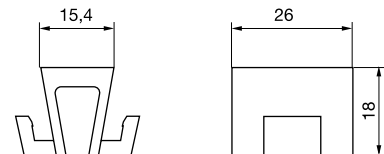
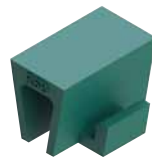

CLIPS

Order code: KLP

Material: Polypropylene

KLP clips allow the assembly of tube supports. The tube supports are clipped together with the clip.

See figures 2 and 3

SCHNECKENGEWINDESCELLEN

Bestellzeichen: SGS

*Bestellzeichen ergänzen:

W1: Stahl verzinkt

W5: Rostfreier Stahl

**Abmessungen nur für eine Rohrleitung auf Rohrlager!

Bei Montage von mehr als einer Rohrleitung auf den Zylinder oder/und Aufbau mit Adapter sind entsprechend größere Schellen zu verwenden!

WORM THREAD CLAMPS

Order Code: SGS

*please add. to order code:

W1: Steel zinc plated

W5: Stainless steel

**Dimensions to use 1 pipe on 1 support!

Use clamps of the correct size when assembling more than one tube on the cylinder or/and when using the adaptor!

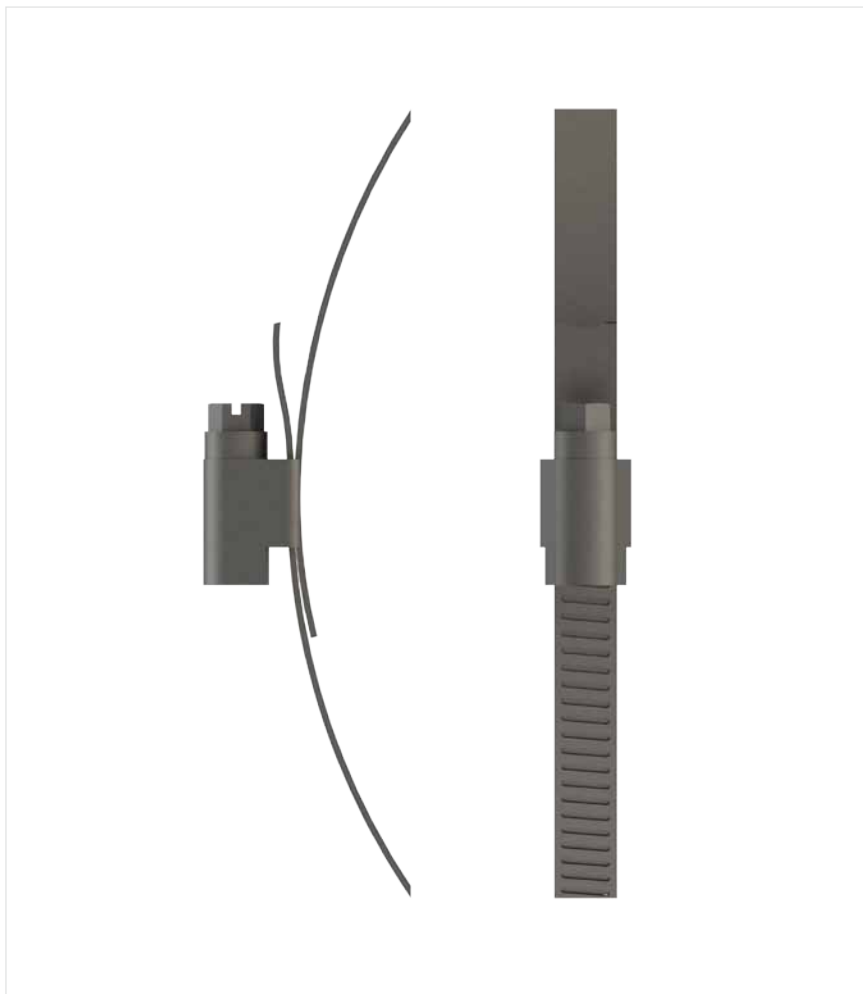

Schneckengewindegewinde nach DIN 3017 / Worm thread clamps DIN 3017

Bandbreite Strip width	Bestellzeichen Order Codes	Passend für Zylinder-Ø** Fits cylinders**
12	SGS-100-120/W*	90 – 110
12	SGS-110-130/W*	100 – 120
12	SGS-120-140/W*	110 – 130
12	SGS-130-150/W*	120 – 140
12	SGS-140-160/W*	130 – 150
12	SGS-150-170/W*	140 – 160
12	SGS-160-180/W*	150 – 170
12	SGS-170-190/W*	160 – 180
12	SGS-180-200/W*	170 – 190
12	SGS-190-210/W*	180 – 200
12	SGS-200-220/W*	190 – 210
12	SGS-210-230/W*	200 – 220
12	SGS-220-240/W*	210 – 230
12	SGS-230-250/W*	220 – 240
12	SGS-240-260/W*	230 – 250
12	SGS-250-270/W*	240 – 260
12	SGS-260-280/W*	250 – 270



Machen Sie Ihre Baumaschinen fit mit HSRS

Hydraulik-Rohrschelle HSRS
 Nachträgliche Anschweißmöglichkeit
 Schwingungsfreies Verlegen von Rohren

Do up your construction machines with HSRS

*Hydraulic steel clamp HSRS
 Weld-on possibility later on
 Vibration-free installation of tubes and hoses*



Die robuste Bauart der Schelle wirkt schlag- und vibrationsdämmend. Ein nachträgliches Verlegen von Hydraulikleitungen – zum Beispiel für den Anbau von Zusatzgeräten an Baumaschinen – ist durch die geringe Höhe der Schelle jederzeit möglich.

Die Schalldämmeinlage sorgt für eine verbesserte Geräuschkämmung und garantiert eine sichere Befestigung empfindlicher Rohr- und Schlauchleitungen.

The robust construction of the clamp provides for impact and vibration reduction. The low height of this clamp type allows hydraulic lines to be installed at any time later on – e.g. for the installation of additional units on construction machines.



The noise protection inlay provides for an improved noise reduction and guarantees the safe fastening of sensitive tubes and host lines.

Sicher und vibrationsdämmend:

Hydraulik-Stahlschelle

Geringer Platzbedarf

Nachträgliche Anschweißmöglichkeit

Schwingungsfreies Verlegen von Rohren

Save and vibration-insulation:

Hydraulic steel clamp

Space-saving system

Can be welded afterwards

Allows vibration-free laying and mounting of tubes

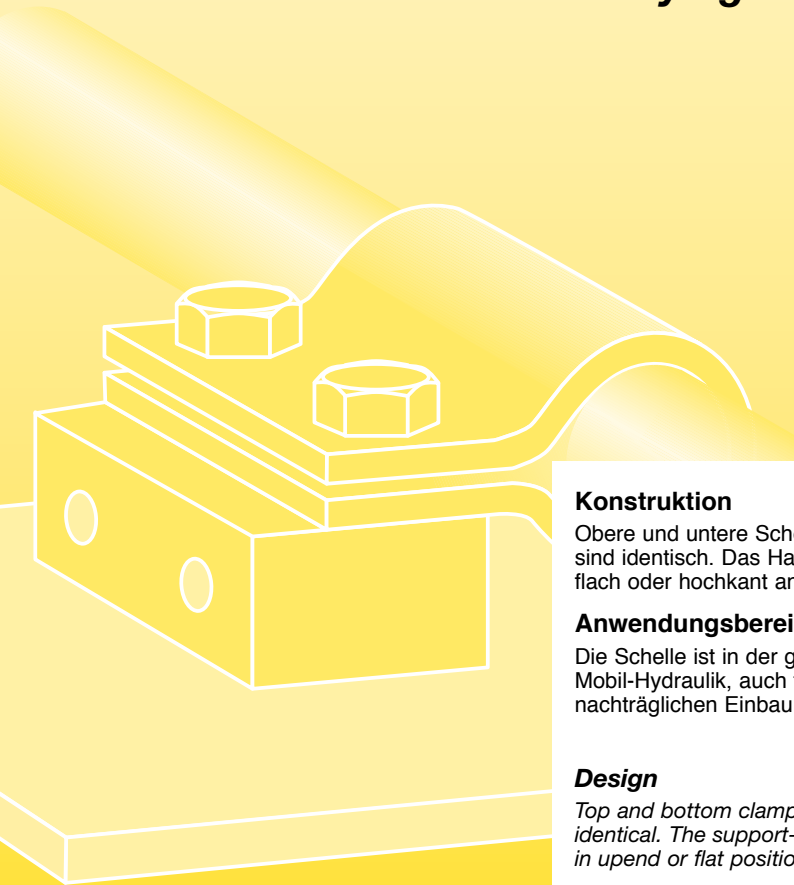

Konstruktion

Obere und untere Schellenhälfte sind identisch. Das Halteteil wird flach oder hochkant angeschweißt.

Anwendungsbereiche

Die Schelle ist in der gesamten Mobil-Hydraulik, auch für den nachträglichen Einbau, einsetzbar.

Design

Top and bottom clamp halves are identical. The support-block is welded in upend or flat position.

Field of application

The clamp is used for the whole mobile hydraulic. The small dimension of the clamp allows hydraulic tubes and hoses to be mounted afterwards.



HYDRAULIK-STAHLSCHELLE

Bestellzeichen: **HSRS-***

W1: Stahl Zn
*mit $\varnothing d_2$ ergänzen

Hydraulik-Stahlschellen HSRS finden vorwiegend im Bereich Baumaschinen Verwendung.

Das Halteteil wird hochkant oder flach aufliegend an den Maschinenkörper oder ein anderes Bauteil geschweißt. Die Rohrschelle wird angeschraubt.

Die robuste Bauart der Schelle wirkt schlag- und vibrationsdämmend. Ein nachträgliches Verlegen von Hydraulikleitungen – zum Beispiel für den Anbau von Zusatzgeräten an Baumaschinen – ist durch die geringe Höhe der Schelle jederzeit möglich.

HYDRAULIC STEEL CLAMP

Order code: **HSRS-***

W1: Steel Zn
*please add. $\varnothing d_2$

HSRS hydraulic steel clamps are mainly used in the field of building machinery.

The support-block is welded to the machine body or another component either in upend or flat position. The tube-clamp is screwed on.

The robust construction of the clamp has an impact- and vibration-insulation effect. The small dimension/ height of the clamp allows hydraulic cables to be fitted on later – e.g. for installing additional equipment to building machinery.

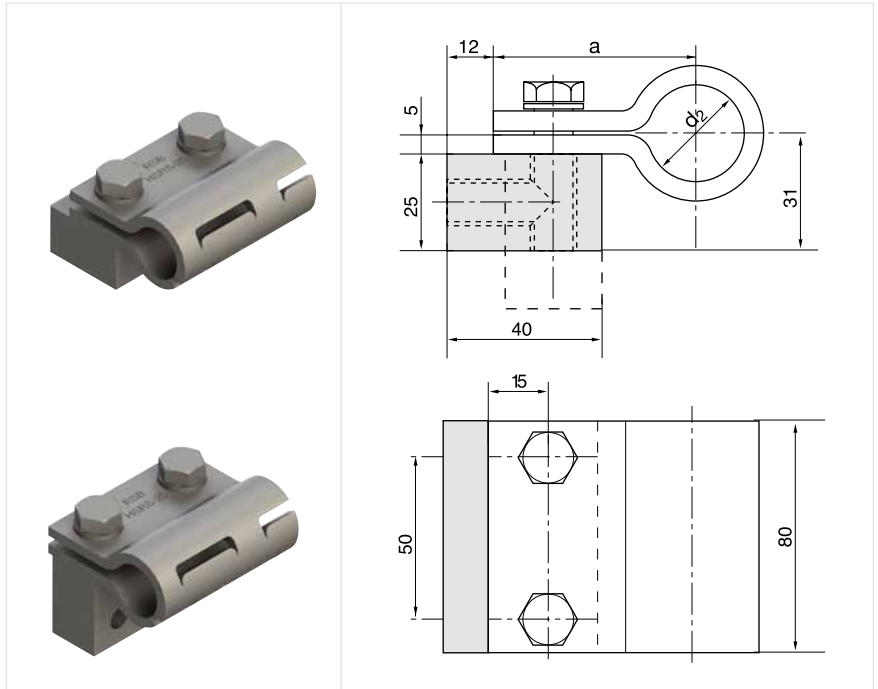

Bestellzeichen Order codes	Maße / Measurement	
	$\varnothing d_2$	a
HSRS-25	25	52,5
HSRS-30	30	55
HSRS-35	35	57,5
HSRS-38	38	59
HSRS-42	42	61
HSRS-48	48	64
HSRS-50	50	65
HSRS-60 ¹⁾	60	70



¹⁾ Halteteil nur hochkant einsetzbar

¹⁾ The support can only be used in upright position

SCHALLDÄMMEINLAGE FÜR HSRS

Bestellzeichen: EE-*

*mit Nenngröße der Schelle und
Rohraußendurchmesser ergänzen

Hydraulik-Stahlschelle HSRS wahlweise
auch mit Schalldämmeinlage.

Vorteil:

- verbesserte Geräusch- und Vibrationsdämmung
- sichere Befestigung auch empfindlicher Rohr und Schlauchleitungen
- mehrere Rohrdurchmesser mit einer Schelle möglich

Werkstoff:

- TPE 64° Shore
- hohe Öl- und Witterungsbeständigkeit,
 - Temperaturbeständigkeit von -40 bis +120°C

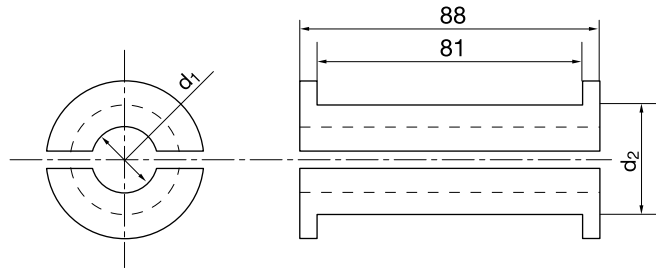

NOISE PROTECTION INSERT FOR HSRS

Order code: EE-*

*complete with nominal clamp size
and outside tube diameter

Hydraulik steel clamp HSRS also available
with noise protection insert.

The advantages:

- improved quality as regards noise and vibration reduction
- safe fastening method even for very sensitive tube and hose lines
- only one clamp for different tube diameters

Material:

- TPE 64° Shore
- high oil and weathering resistance
 - Temperature stability between -40°C and +120°C

Bestellzeichen Order Codes	Schelle Nenngröße Nominal size d ₂	Rohr-Ø mm Tube Ø mm d ₁
EE 25-12	HSRS-25	12
EE 25-15		15
EE 30-20	HSRS-30	20
EE 35-25	HSRS-35	25
EE 42-30	HSRS-42	30
EE 50-35	HSRS-50	35
EE 50-38		38
EE 50-42		42
EE 60-47	HSRS-60	47
EE 60-50		50



Stahl-Konstruktionsschelle mit Rohrunterlagen

*Steel-construction clamp with
tube saddles*



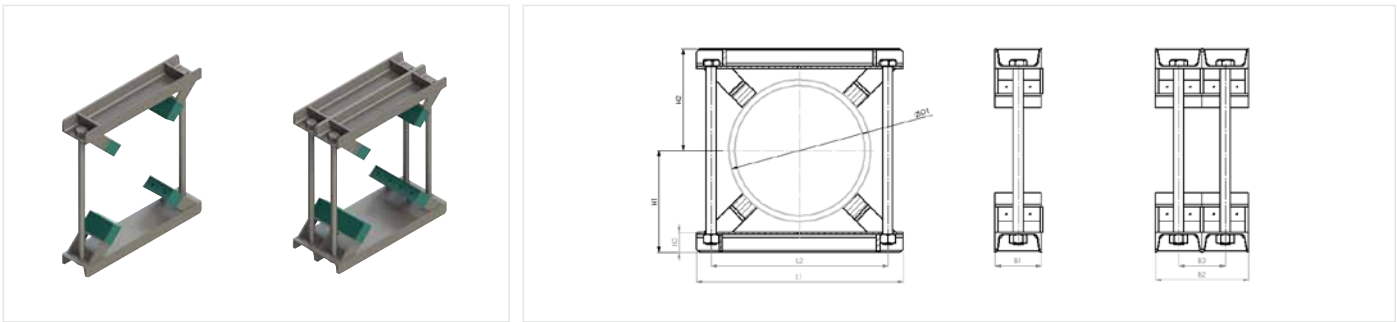

Rohr-AD mm O.D.mm D1	Stahl-Konstruktionsschelle Steel-construction clamp								Sechskantschraube Hexagon head screw	Anzahl der Rohrunterlagen Number of tube saddles
	L1	L2	H1	H2	H3	B1	B2	B3		
220 – 275	420	330	220	220	60	140	280	140	M30 x 370	4
276 – 325	460	370	240	240	60	140	280	140	M30 x 410	4
326 – 370	510	420	260	260	60	140	280	140	M30 x 450	4
371 – 425	570	480	290	290	60	140	280	140	M30 x 510	4
426 – 485	620	530	305	305	60	140	280	140	M30 x 540	4
486 – 550	680	590	370	370	60	140	280	140	M30 x 670	4
551 – 630	760	670	410	410	60	140	280	140	M30 x 750	5
631 – 715	845	755	452	452	60	140	280	140	M30 x 840	5
716 – 800	940	850	495	495	60	140	280	140	M30 x 920	5

BESTELLBEISPIEL
EXAMPLE FOR ORDER

RKP-355,6/CRVIF
 RKP-273/Zn

RK | **P** | **-** | **220** | **/** | **CRVIF**

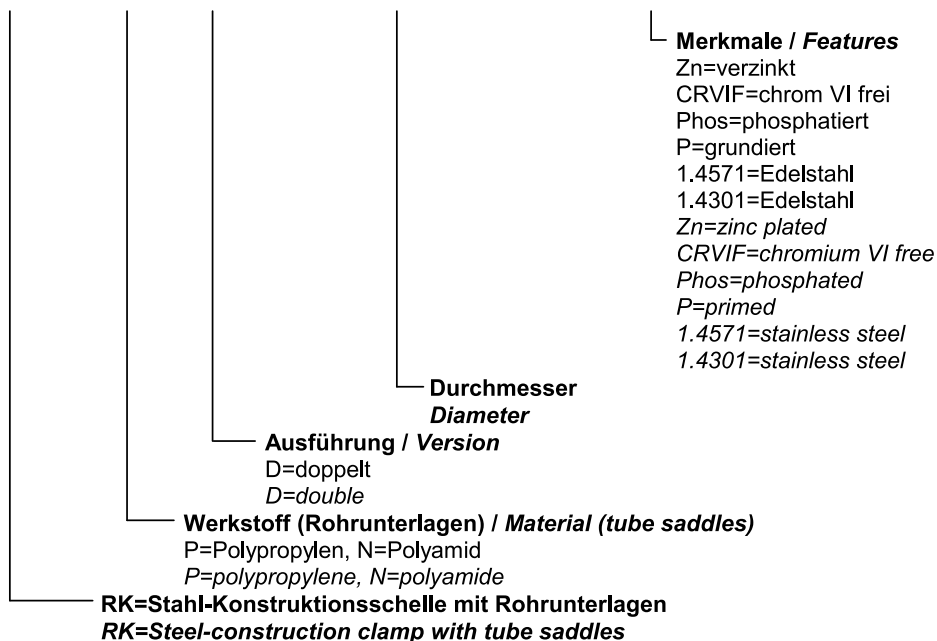

Flachstahlbügel

Flat Steel U-Bolts

Einsatzbereich

Flachstahlbügel sind nur als Festpunkt-Befestigung einsetzbar

Ausführung

Flachstahlbügel mit U-Profil und kurzer Rohrunterlage KUPK.

Flachstahlbügel sind für Rohrdurchmesser von 48,3 bis 521 mm lieferbar.

Die Rohrunterlagen werden aus Polypropylen und Polyamid hergestellt.

Area of application

Flat Steel-U-bolts are to be used as fixed point-fastening only.

Konstruktion

Flat Steel U-Bolts with U-profile and short tube-saddle KUPK.

Flat Steel U-Bolts are available for tube diameters from 48,3mm to 521 mm.

The Tube saddles are made of polypropylene and polyamide.

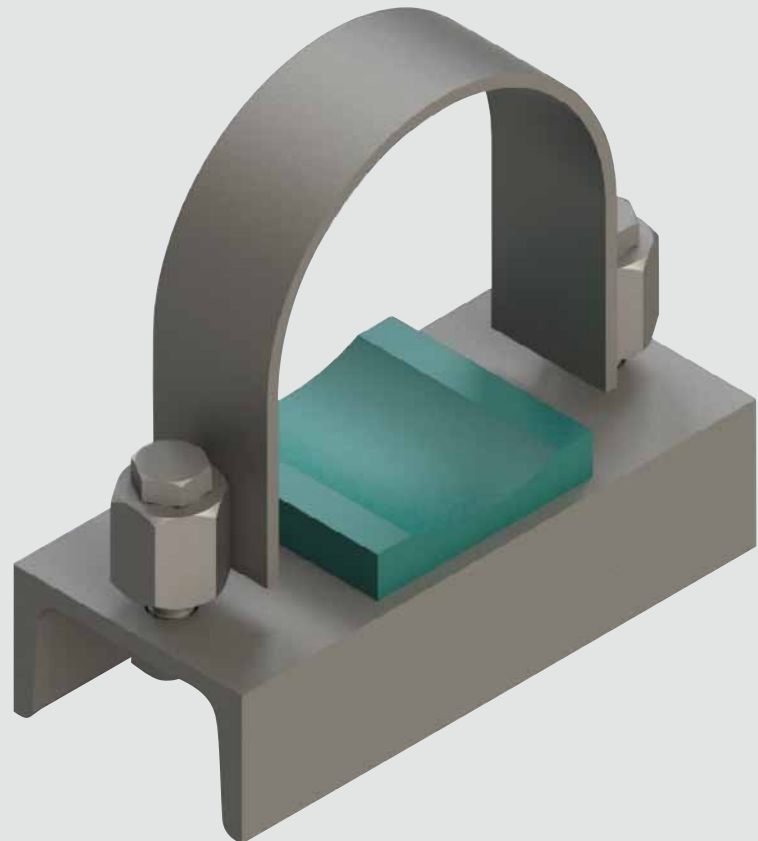

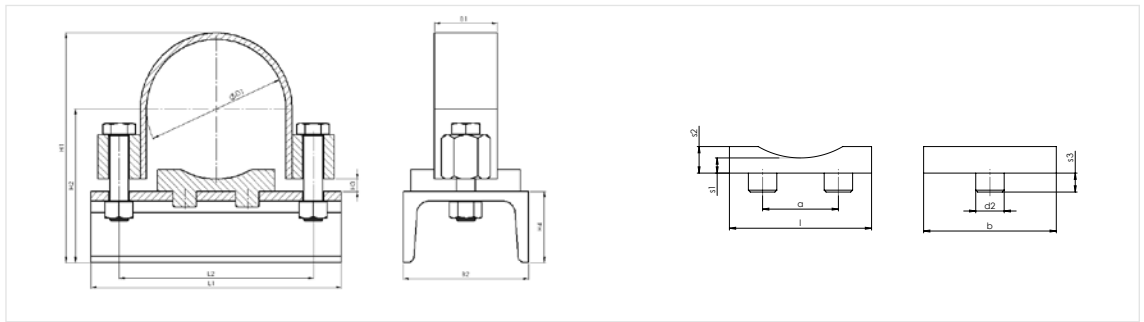
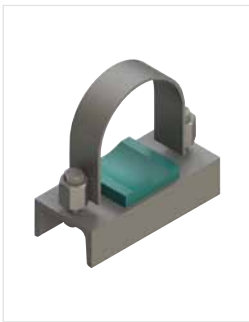

Nenngr. Nom. size	für Rohr for tube		Flachstahlbügel Flat Steel U-bolts							U-Profil u-profile	Rohrunterlage, kurz Tube saddle, short						Sechskantschraube Hexagon head screw	
	D1	NW	L1	L2	H1	H2	H3	B1	B2 x H4		l	a	b	d2	s1	s2		s3
40	48,3	1 1/2"	103	78	94	67					24		35	8		8	5	M10 x 40
50	57		115	87	103	71,5	5	20 x 3	DIN 1026 50 x 38	38	25	50	10	5	10	6		
	60,3	2"		90,3	106,3	73,2												
65	76,1	2 1/2"	132	106,1	122,1	81,1												M12 x 55
80	88,9	3"	160	123,9	146	97,5												
	100	108		170	143	165												
125	133		205	168	190	119,5												
	150	159		174,7	197	123												
150	159		255	207	218	132,5	8	40 x 6	DIN 1026 80 x 45	140	90		25		8		10	
	175	168,3		265	216,3	227,3												137,2
200	193,7		290	241,7	252,7	149,9												
	250	216		315	264	275												161
250	219,1	8"	375	267	278	162,5												
	300	267		380	324	328												186,5
300	273	10"	430	330	334	189,5												
	350	318		375	379	212												
350	323,9	12"	475	380,9	384,9	215												
	400	355,6		485	430	434												242
400	368		540	468,4	472,4	261,2	12	60 x 8	DIN 1026 100 x 50	220	150		30		30			
	500	406,4		575	519	523												286,5
500	419		625	481	485	267,5												
	521	457		575	519	523												286,5
	508	20"	625	570	574	312												
	521		635	583	587	318,5												

**BESTELLBEISPIEL
EXAMPLE FOR ORDER**

RUBF-88,9/Zn/KUPK-80

RUB F - 60,3 / CRVIF / KUPK - 50

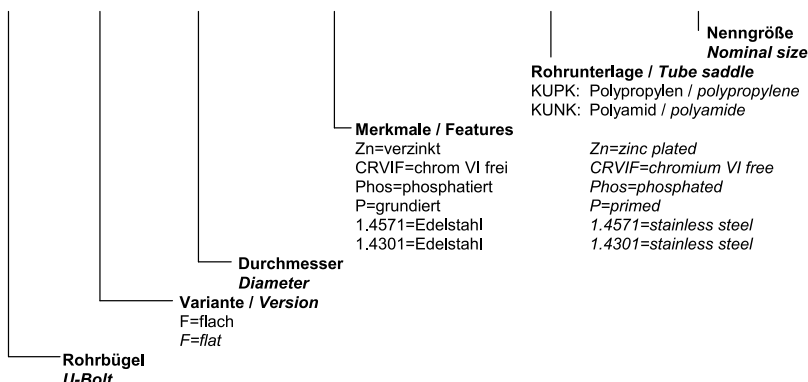

Rundstahlbügel mit Rohrunterlage Flachstahl-Rohrschelle

Stahl, verzinkt und Edelstahl

U-Bolt with tube saddle Flat steel tube clamp

steel, galvanized steel and stainless steel

Einsatzbereich

Eignung besonders zum Befestigen von Rohren mit Wärmeausdehnung. Die Rohre können mit dem Bügel wahlweise fest verspannt, oder mit Gleitspiel versehen werden.

Ausführung

Rundstahlbügel sind in zwei Ausführungen lieferbar:

RUBD Rundstahlbügel DIN 3570 mit 2 Muttern und **RUBL** Rundstahlbügel mit 4 Muttern unter Verwendung mit **KUPK** oder **KUPL** Rohrunterlagen. Rundstahlbügel sind für Rohrdurchmesser von 17 bis 762 mm lieferbar.

Die Rohrunterlagen werden in kurzer oder langer Ausführung aus Polypropylen und Polyamid hergestellt.

Area of application

Especially suitable for securing tubes with heat expansion. The tubes can be braced firmly to the bow or, alternatively, slide along grooves.

Construction

U-Bolts are available in two designs:

RUBD DIN 3570 with 2 nuts and **RUBL** U-Bolts with 4 nuts to be used with tube saddle **KUPK** or **KUPL**. U-Bolts are available for tube diameters from 17 to 762 mm.

The tube saddle are made of polypropylene and polyamide and are produced in a short or long version.

Rundstahlbügel mit Rohrunterlage lang
U-Bolt with tube saddle long



Rundstahlbügel mit Rohrunterlage kurz
U-Bolt with tube saddle short



Rundstahlbügel
U-Bolt



Flachstahl-Rohrschelle
Flat steel tube clamp



Bestellzeichen:

Stahl **RUBD-25/38**
Stahl verzinkt **RUBD-25/38Zn**
Edelstahl 1.4571 **RUBD-25/38/1.4571**

Order codes:

Steel **RUBD-25/38**
Steel zinc plated **RUBD-25/38Zn**
Stainless steel 1.4571 **RUBD-25/38/1.4571**

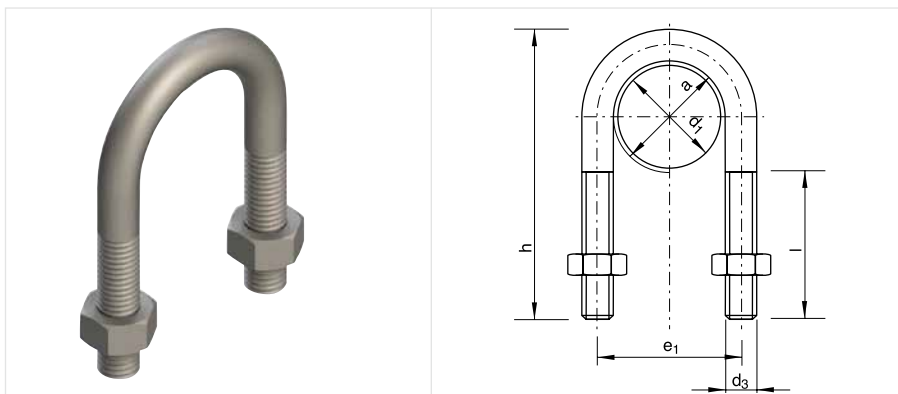

Nenngröße Nominal size	für Rohr for tube		Bestellzeichen Order Codes	a	l	d ₃	e ₁	h
	NW	d ₁						
15	3/8"	17,2	RUBD-15/24	24	40	M 10	34	65
	1/2"	21,3						
20	3/4"	25	RUBD-20/30	30	40	M 10	40	70
25	1"	30 33,7	RUBD-25/38	38			48	76
32	1 1/4"	38 42,4	RUBD-32/46	46	50	M 12	56	86
40	1 1/2"	44,5 48,3	RUBD-40/52	52			62	92
50	2"	57 60,3	RUBD-50/64	64	50	M 12	76	109
65	2 1/2"	76,1	RUBD-65/82	82			94	125
80	3"	88,9	RUBD-80/94	94	60	M 16	106	138
100	4"	108 114,3	RUBD-100/120	120			136	171
125	5"	133 139,7	RUBD-125/148	148	60	M 16	164	191
150	6"	159 168,3	RUBD-150/176	176			192	217
175		193,7	RUBD-175/202	202	70	M 20	218	249
200	8"	216 219,1	RUBD-200/228	228			248	283
250	10"	267 273	RUBD-250/282	282	70	M 20	302	334
300	12"	318 323,9	RUBD-300/332	332			352	385
350	14"	355,6 368	RUBD-350/378	378	70	M 24	402	435
400	16"	406,4 419	RUBD-400/428	428			452	487
500	20"	508 521	RUBD-500/530	530			554	589

Rundstahlbügel sind mit Rohrunterlagen kombinierbar. Bügel und Rohrunterlagen können auch einzeln bezogen werden.
RUBD mit KUPK oder KUPL sind als Gleit- und Festpunkt-Befestigung einsetzbar.
Lieferbar: ohne Oberflächenbehandlung, verzinkt und Edelstahl.

U-Bolts be combined with Tube saddles. U-bolts and Tube saddles are also available in single pieces.
RUBD with KUPK or KUPL may be used as glide- or fixed point-fastening.
Available: without surface treatment, galvanized and stainless steel.



Bestellzeichen:

Stahl **RUBL-25/38**
 Stahl verzinkt **RUBL-25/38Zn**
 Edelstahl 1.4571 **RUBL-25/38/1.4571**

Order codes:

Steel **RUBL-25/38**
 Steel zinc plated **RUBL-25/38Zn**
 Stainless steel 1.4571 **RUBL-25/38/1.4571**

Rundstahlbügel ähnlich DIN 3570
 U-Bolts similar to DIN 3570

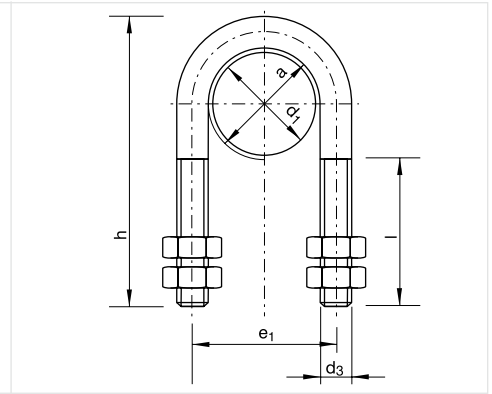

Nenngröße Nominal size	für Rohr for tube		Bestellzeichen Order Codes	a	l	d ₃	e ₁	h
	NW	d ₁						
15	3/8"	17,2	RUBL-15/24	24	40	M 10	34	70
	1/2"	21,3						
20	3/4"	25	RUBL-20/30	30	46	M 10	40	73,5
	1"	26,9						
25	1"	30	RUBL-25/38	38	50	M 10	48	81
	1 1/4"	33,7						
32	1 1/4"	38	RUBL-32/46	46	55	M 10	56	89
	1 1/2"	42,4						
40	1 1/2"	44,5	RUBL-40/52	52	63	M 12	62	100
	2"	48,3						
50	2"	57	RUBL-50/64	64	77	M 12	76	118
	2 1/2"	60,3						
65	2 1/2"	76,1	RUBL-65/82	82	82	M 12	94	135
	3"	88,9						
80	3"	108	RUBL-80/94	94	105	M 16	106	152
	4"	114,3						
100	4"	133	RUBL-100/120	120	125	M 16	136	190
	5"	139,7						
125	5"	159	RUBL-125/148	148	145	M 20	164	217
	6"	168,3						
150	6"	193,7	RUBL-150/176	176	175	M 24	192	247
	8"	193,7						
175	8"	216	RUBL-175/202	202	175	M 24	218	273
	10"	219,1						
200	10"	267	RUBL-200/228	228	145	M 24	248	311
	12"	273						
250	12"	318	RUBL-250/282	282	175	M 30	302	364
	14"	323,9						
300	14"	355,6	RUBL-300/332	332	175	M 30	352	418
	16"	368						
350	16"	406,4	RUBL-350/378	378	175	M 30	402	475
	18"	419						
400	18"	508	RUBL-400/428	428	175	M 30	452	526
	20"	521						
500	20"	558,8	RUBL-500/530	530	175	M 30	554	627
	22"	521						
550	22"	609,6	RUBL-550/570	570	175	M 30	600	689
	24"	622						
600	24"	660,4	RUBL-600/622	622	175	M 30	652	741
	26"	660,4						
650	26"	711,2	RUBL-650/680	680	175	M 30	710	795
	28"	711,2						
700	28"	762	RUBL-700/730	730	175	M 30	760	845
	30"	762						
750	30"	762	RUBL-750/785	785	175	M 30	815	898

Rundstahlbügel sind mit Rohrunterlagen kombinierbar. Bügel und Rohrunterlagen können auch einzeln bezogen werden.
 RUBL mit KUPK oder KUPL sind als Gleit- und Festpunkt-Befestigung einsetzbar.
 Lieferbar: ohne Oberflächenbehandlung, verzinkt und Edelstahl.

U-Bolts be combined with Tube saddles. U-bolts and Tube saddles are also available in single pieces.
 RUBL with KUPK or KUPL may be used as glide- or fixed point-fastening.
 Available: without surface treatment, galvanized and stainless steel.



Bestellzeichen:

Polypropylen **KUPL**
Polyamid 6 **KUNL**

Bei Bedarf Standardkurzzeichen KUPL in der Spalte „Bestellzeichen“ austauschen.

Order codes:

Polypropylene **KUPL**
Polyamide 6 **KUNL**

Replace standard abbreviation KUPL in column "Order codes" as required.

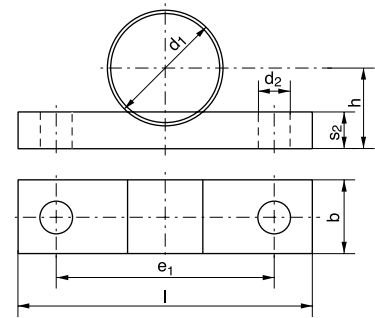

Nenngröße Nominal size	für Rohr for tube		Bestellzeichen Order Codes	l	b	s ₂	h	e ₁	d ₂
	NW	d ₁							
15	3/8"	17,2	KUPL-15/17,2	60	25	10	13,5	34	
	1/2"	21,3	KUPL-15/21,3				15,5		
20	3/4"	25	KUPL-20/25	75			17,5	40	
		26,9	KUPL-20/26,9				18,5		
25	1"	30	KUPL-25/30	80	30	12	20	48	11
		33,7	KUPL-25/33,7				22		
32	1 1/4"	38	KUPL-32/38	90			24	56	
		42,4	KUPL-32/42,4				26,2		
40	1 1/2"	44,5	KUPL-40/44,5	95			27,2	62	
		48,3	KUPL-40/48,3				29		
50	2"	57	KUPL-50/57	110	35	15	33,5	76	
		60,3	KUPL-50/60,3				35,2		
65	2 1/2"	76,1	KUPL-65/76,1	135			43	94	14
		88,9	KUPL-80/88,9				54,5		
100	4"	108	KUPL-100/108	190	40	20	64	136	
		114,3	KUPL-100/114,3				67		
125	5"	133	KUPL-125/133	220			76,5	164	18
		139,7	KUPL-125/139,7				80		
150	6"	159	KUPL-150/159	250			91,5	192	
		168,3	KUPL-150/168,3				96		
175		193,7	KUPL-175/193,7	270			109	218	
200	8"	216	KUPL-200/216	315	50	25	120	248	
		219,1	KUPL-200/219,1				121,5		
250	10"	267	KUPL-250/267	370			145,5	302	22
		273	KUPL-250/273				148,5		
300	12"	318	KUPL-300/318	420			174	352	
		323,9	KUPL-300/323,9				177		
350	14"	355,6	KUPL-350/355,6	480	60	30	193	402	
		368	KUPL-350/368				199		
400	16"	406,4	KUPL-400/406,4	540			218	452	26
		419	KUPL-400/419				224,5		
500	20"	508	KUPL-500/508	640			269	554	
		521	KUPL-500/521				276		
550		558,8	KUPL-550/558,8	700			300	600	
600		609,6	KUPL-600/609,6	750			325	652	
650		660,4	KUPL-650/660,4	810	70	40	350	710	33
700		711,2	KUPL-700/711,2	870			376	760	
750		762	KUPL-750/762	910			401	815	

Bestellzeichen:

Polypropylen **KUPK**
Polyamid 6 **KUNK**

Bei Bedarf Standardkurzzeichen KUPK in der Spalte „Bestellzeichen“ austauschen.

Order codes:

Polypropylene **KUPK**
Polyamide 6 **KUNK**

Replace standard abbreviation KUPK in column "Order codes" as required.

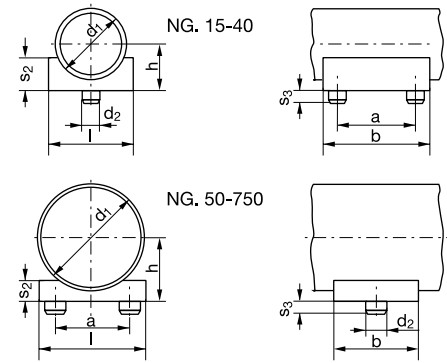

Nenngröße Nominal size	für Rohr for tube		Bestellzeichen Order Codes	l	b	s ₂	h	a	d ₂	s ₃																																																																		
	NW	d ₁									KUPK																																																																	
15	3/8"	17,2	KUPK-15/17,2	24	35	8	13,6	25	8	5																																																																		
	1/2"	21,3	KUPK-15/21,3				15,65																																																																					
20	3/4"	25	KUPK-20/25				38				50	10	17,5	40	15	6																																																												
		26,9	KUPK-20/26,9										18,45																																																															
25	1"	30	KUPK-25/30										75				70	14	20	90	25	10																																																						
		33,7	KUPK-25/33,7																21,85																																																									
32	1 1/4"	38	KUPK-32/38																140				75	30	24	150	30	10																																																
		42,4	KUPK-32/42,4																						26,2																																																			
40	1 1/2"	44,5	KUPK-40/44,5																						220				75	30	27,25	220	30	10																																										
		48,3	KUPK-40/48,3																												29,15																																													
50	2"	57	KUPK-50/57																												300				75	38	33,5	220	30	10																																				
		60,3	KUPK-50/60,3																																		35,15																																							
65	2 1/2"	76,1	KUPK-65/76,1																																		300				75	38	43,05	220	30	10																														
		80	KUPK-80/88,9																																								52,45																																	
100	4"	108	KUPK-100/108																																								300				75	38	62	220	30	10																								
		114,3	KUPK-100/114,3																																														65,15																											
125	5"	133	KUPK-125/133																																														300				75	38	74,5	220	30	10																		
		139,7	KUPK-125/139,7																																																				77,85																					
150	6"	159	KUPK-150/159																																																				300				75	38	87,5	220	30	10												
		168,3	KUPK-150/168,3																																																										92,15															
175	8"	193,7	KUPK-175/193,7																																																										300				75	38	104,85	220	30	10						
		200	KUPK-200/216																																																																116									
200	8"	216	KUPK-200/216																																																																300				75	38	117,55	220	30	10
		219,1	KUPK-200/219,1																																																																						141,5			
250	10"	267	KUPK-250/267	300	75	38		144,5	220	30																																																															10			
		273	KUPK-250/273					167																																																																				
300	12"	318	KUPK-300/318				300	75			38	169,95		220	30	10																																																												
		323,9	KUPK-300/323,9									185,8																																																																
350	14"	355,6	KUPK-350/355,6									300	75				38	192		220	30	10																																																						
		368	KUPK-350/368															211,2																																																										
400	16"	406,4	KUPK-400/406,4															300	75				38	217,5		220	30	10																																																
		419	KUPK-400/419																					262																																																				
500	20"	508	KUPK-500/508																					300	75				38	268,5		220	30	10																																										
		521	KUPK-500/521																											287,4																																														
550	20"	558,8	KUPK-550/558,8																											300	75				38	312,8		220	30	10																																				
		609,6	KUPK-600/609,6																																	338,2																																								
600	20"	609,6	KUPK-600/609,6																																	300	75				38	363,6		220	30	10																														
		660,4	KUPK-650/660,4																																							389																																		
650	20"	660,4	KUPK-650/660,4																																							300	75				38	363,6		220	30	10																								
		711,2	KUPK-700/711,2																																													389																												
700	20"	711,2	KUPK-700/711,2																																													300	75				38	389		220	30	10																		
		762	KUPK-750/762																																																			389																						

Bestellzeichen:

Stahl **FRD-521A**
Stahl verzinkt **FRD-521AZn**
Edelstahl 1.4571 **FRD-521A/1.4571**

Order codes:

Steel **FRD-521A**
Steel zinc plated **FRD-521AZn**
Stainless steel 1.4571 **FRD-521A/1.4571**

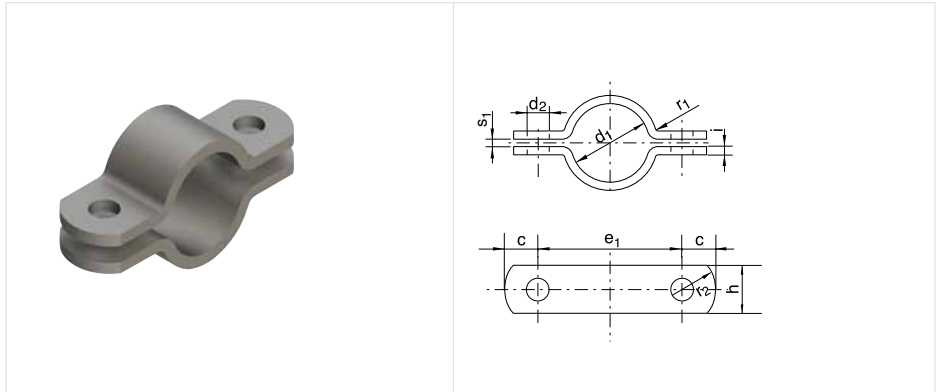

Nenngröße Nominal size	Bestellzeichen Order Codes	Für Rohr Nennweite For tube NB	Maße Measurements								erforderl. Schrauben mit Mutter Matching screws with nut	
			e ₁	c	d ₂	s ₁	r ₁	r ₂	h	i		
20	FRD-20 A		57									
22	FRD-22 A	15	1/2"	59								
25	FRD-25 A			62								
27	FRD-27 A	20	3/4"	66								
30	FRD-30 A			68								
34	FRD-34 A	25	1"	72	15	11,5	7	4	18	30	5	M 10 x 30
38	FRD-38 A			76								
43	FRD-43 A	32	1 1/4"	82								
45	FRD-45 A			84								
49	FRD-49 A	40	1 1/2"	88								
57	FRD-57 A			104								
61	FRD-61 A	50	2"	108								
77	FRD-77 A	65	2 1/2"	122	18	14	9	6	24	40	6	M 12 x 35
89	FRD-89 A	80	3"	136								
108	FRD-108 A			172								
115	FRD-115 A	100	4"	178								
133	FRD-133 A			196								
140	FRD-140 A	125	5"	204								
159	FRD-159 A			222								
169	FRD-169 A	150	6"	232	24	18	11	6	30	50	8	M 16 x 45
191	FRD-191 A			254								
194	FRD-194 A	175		258								
216	FRD-216 A			280								
220	FRD-220 A	200	8"	284								
267	FRD-267 A			342								
273	FRD-273 A	250	10"	348								
318	FRD-318 A			392								
324	FRD-324 A	300	12"	398	30	23	14	8	36	60	8	M 20 x 50
356	FRD-356 A			432								
368	FRD-368 A	350		444								
407	FRD-407 A			498								
419	FRD-419 A	400	16"	510								
508	FRD-508 A			600	36	27	18	8	42	70	10	M 24 x 60
521	FRD-521 A	500		614								

Lieferbar: ohne Oberflächenbehandlung, verzinkt und Edelstahl.
Available: without surface treatment, galvanized and stainless steel.



Bezeichnungssystem

Flexible Montage, informative Kennzeichnung,
variabler Anwendungsbereich

Labeling system

Flexible assembly, informative symbols,
variable areas of application

Das System

Das RSB-Bezeichnungssystem besteht aus Schilderhalterungen, an welchen die Bezeichnungsschilder durch Aufklipsen der Schutzabdeckung befestigt werden.

Einsatzbereich

Die Vielfalt der Befestigungsmöglichkeiten, von der einfachen Schraubmontage über Spannbänder, bis zur speziellen Halterung für isolierte Rohre, ermöglicht alle in der Praxis vorkommenden Bezeichnungsarten:

- Gebäudeinstallation mit Gas-, Wasser-, Elektro- und Heizungsanlagen
- industrielle Installation in der Schiffs-, Flug- und Bergwerktechnik, sowie im Hydraulik- und Schaltanlagenbereich

Haltbarkeit

Durch die Schutzwirkung der Abdeckkappe sind die Informationen auch noch nach Jahren lesbar. Sie sind leicht zu reinigen oder auszuwechseln und bieten einen optimalen Schutz vor Umwelteinflüssen.

Werbung

Das RSB-Bezeichnungssystem ist die Visitenkarte des Unternehmens und werbewirksame Präsentation des ausführenden Betriebes.

The system

The RSB-Labeling System consists of plates support and cover, into which the engraved plate of solid or double layer material is inserted.

Areas of application

The versatility of fixing possibilities, from the simplest screw assembly via straps to special supports for insulated tubes, enables every in practice occurring type of labelling:

- Building systems with gas, water, electro and heating installations
- industrial installations in the naval, aero and mining technology, as well as in the hydraulic and switchgear field

Stability

The protective effect of the cover ensures that the data is still legible, even after years. It can easily be cleaned or changed and offers optimal protection against environmental influences.

Schweißhalter
Welding holder

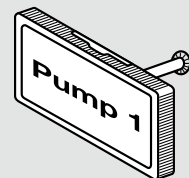

Universalhalter
Tragschienenmontage
Universal holder
support on rails

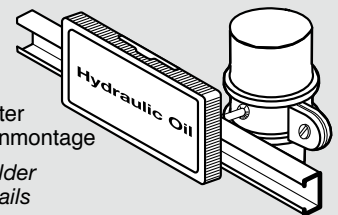

Universalhalter
mit Spannband
Universal holder
with strap

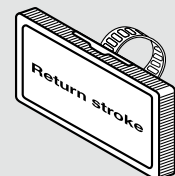

Schraubhalter
Screw holder

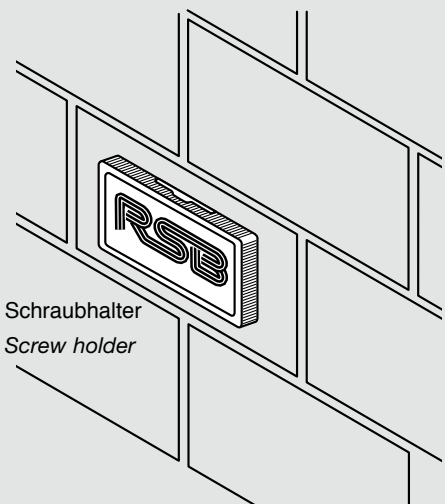

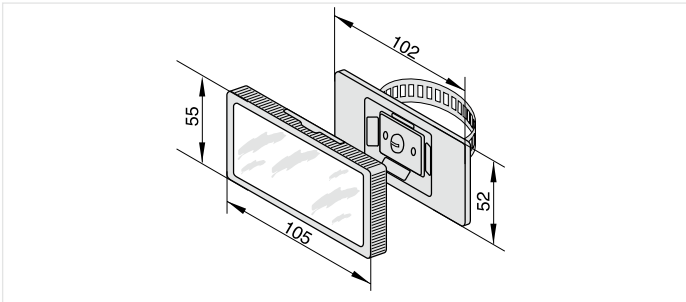

Universalhalter / Universal holder
 Komplet mit Kunststoffabdeckung und verzinktem Spannband.
 Passend für Rohre bis 2 1/2".
 Complete with plastic cover and galvanized steel strap.
 For tubes up to 2 1/2".
 Bestellzeichen / Order code: **UNH**
 Verpackung 25 Stück / Packs of 25

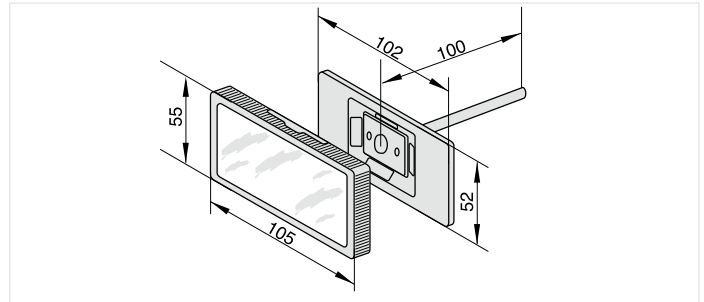

Schweißhalter / Welding holder
 Komplet mit Kunststoffabdeckung und Anschweißstift 100 mm lang.
 Complete with plastic cover and 100 mm welding pin.
 Bestellzeichen / Order code: **SWH**
 Verpackung 25 Stück / Packs of 25

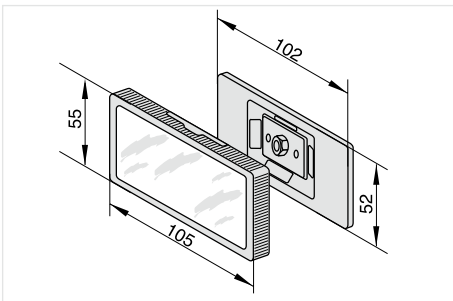

Schraubhalter / Screw holder
 Komplet mit Kunststoffabdeckung, angenieteter Mutter M 8 und zwei zusätzlichen Schraublöchern Ø 4 mm.
 Complete with plastic cover, M 8 nut and two additional screw holes 4 mm in diameter.
 Bestellzeichen / Order code: **SRH**
 Verpackung 25 Stück / Packs of 25

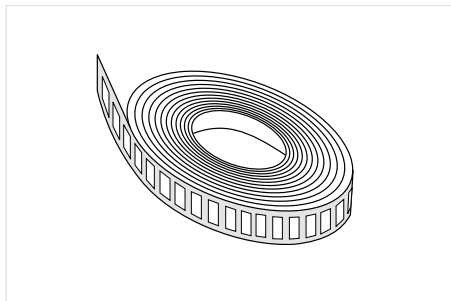

Spannband / Strap
 Passend für Universalhalter.
 Einsatz für Rohre > 2 1/2".
 Suitable for the universal holder.
 Use with tubes > 2 1/2".
 Bestellzeichen / Order code:
 Stahl verzinkt / Galvanized steel: **SPR/Zn**
 Edelstahl / Stainless steel 1.4571: **SPR/1.4571**
 Verpackung 1 Rolle á 5 m / Packed in 5 m rolls

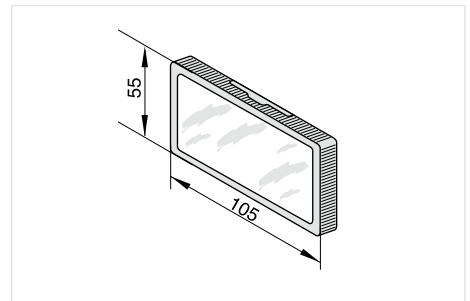

Kunststoffabdeckung / Plastic cover
 Glasklar, passend zu allen Haltertypen.
 Transparent, suitable for all holder types.
 Bestellzeichen / Order code: **KAD**
 Verpackung 50 Stück / Packs of 50

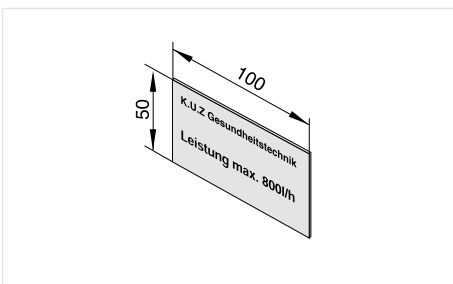

Schild graviert / Engraved plate
 Zweischicht-Kunststoff, Schrift weiß, graviert nach Kundenwunsch.
 Double-layer plastic, white lettering, engraved to order.
 Bestellzeichen-Farben / Order codes-colours:
SGR-rot/red
SGR-blau/blue
SGR-grün/green
SGR-gelb/yellow
 Verpackung 25 Stück / Packs of 25

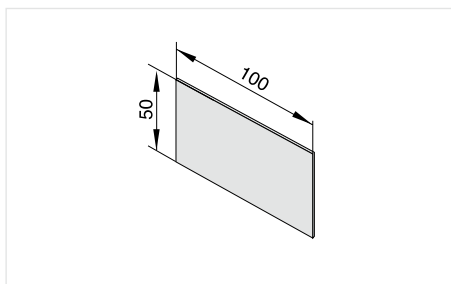

Schild glatt / Smooth plate
 Glatte Oberfläche zum Aufkleben von Prägebändern.
 Smooth surface for the adhesion of stamped strips.
 Bestellzeichen-Farben / Order codes-colours:
SGL-rot/red
SGL-blau/blue
SGL-grün/green
SGL-gelb/yellow
 Verpackung 25 Stück / Packs of 25

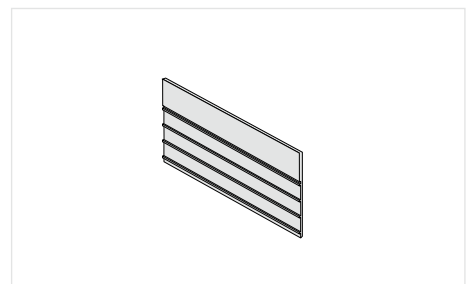

Leerschild mit Nuten / Empty grooved plate
 Mit Nuten zum Einschieben von Prägebändern 9,5 mm.
 With grooves for inserting stamped strips 9,5 mm.
 Bestellzeichen-Farben / Order codes-colours:
SNU-rot/red
SNU-blau/blue
SNU-grün/green
SNU-gelb/yellow
 Verpackung 25 Stück / Packs of 25

Metalteile auch in Edelstahl lieferbar.
 All metal parts available in stainless steel.



WIR ÜBER UNS

WE ABOUT US



Wir ...

... sind ein mittelständisches Unternehmen der Feinwerktechnik, Kunststoffverarbeitung und Beleuchtungstechnik.

... stanzen, biegen, schweißen auf modernsten Maschinen. Unser Know-how in der spanlosen Fertigung macht uns zu einem leistungsfähigen Hersteller in der Blechverarbeitung. Die spanabhebende Fertigung gibt uns die Möglichkeit, spezielle Kundenwünsche schnell zu realisieren. Flexibilität ist die Stärke unserer Kunststoffverarbeitung.

... vereinen drei Produktbereiche in unserem Haus:

- **RSB** -Rohrschellen
- **TECHMALUX**®-Lichttechnik
- **rsb** -Dentaltechnik

We ...

... operate a medium-sized business in the field of precision engineering, plastics processing and lighting engineering.

... stamp, bend, weld on state-of-the-art-machines. Our know-how in the field of chipless production makes us an efficient manufacturer in sheet metal processing. Our cutting shaping equipment allows us to realise our customers' wishes without delay. Our plastics processing's strength lies in its flexibility.

... combine three product ranges under one roof:

- **RSB** -Tube Clamps
- **TECHMALUX**®-Lighting Technology
- **rsb** -Dental Technology



GmbH

SO ERREICHEN SIE UNS

THAT'S HOW TO GET TO US



Oberndorf is situated in the Neckartal, a valley conveniently situated between the Black Forest and the Swabian mountains and has an own junction to the A 81, the federal motorway between Stuttgart and the Western part of the Lake Constance region. Oberndorf is situated between cities of Rottweil and Horb.

The railway system is connected to all major cities in the surrounding region well as to Switzerland and Italy.

Oberndorf liegt im Neckartal, zwischen Schwarzwald und Schwäbischer Alb, verkehrsgünstig an der BAB Stuttgart – Westlicher Bodensee (A 81) mit eigener Anschlussstelle und an der B 14 zwischen Rottweil und Horb.

Es bestehen Bahnverbindungen zu allen größeren Städten der Umgebung, sowie in die Schweiz und Italien.

WWW.FKB-GMBH.COM



**Feinwerktechnik
Kunststoffverarbeitung
Beleuchtungstechnik**

Wehrstrasse 15/27
D-78727 Oberndorf
www.fkb-gmbh.com

Tel. +49 (0) 74 23/92 98-0
Fax +49 (0) 74 23/92 98-55
fkf@fkf-gmbh.com